

RDP: Averaging relay

Areas of application

Formation of the average of two pneumatic input signals in pneumatic control systems.

Features

- 2 input signals are added together and averaged in the relay
- Controller front panel is printed with circuit diagram for rapid identification of function
- Thermoplastic housing suitable for wall or top-hat rail mounting
- Compressed air connections with Rp 1/8" female thread
- Complies with directive 97/23/EC Art. 3.3 on pressure equipment



T03051

Technical description

- Supply pressure 1.3 bar ± 0.1
- 2 input signals
- 1 output signal



Y03179

Type	Description	Air output	Air consumption 2)	Weight kg
RDP 80 F001	averaging relay	400 l _n /h	4 l _n /h	0,15
Supply pressure 1)	1,3 bar ± 0,1	Permissible ambient temp.		0...55 °C
Input pressure	0...1,4 bar	Connection diagram		A02893
Output pressure	0...1,4 bar	Dimension drawing		M297107
		Fitting instructions		MV 3252

Accessories

- 0296936 000*** Fixing bracket for rail EN 60715, 35 × 7,5 and 35 × 15
- 0297113 000*** Manometer bracket for fitting two XMP includes kit; MV 3255
- 0297091 000*** Cover for spare apertures (for manometers), when 0297113 is used

*) Dimension drawing or wiring diagram are available under the same number

- 1) See Section 60 on regulations concerning the quality of supply air, especially at low ambient temperatures
- 2) Without transducer. Air consumption for transducer: an additional 33 l_n/h each for connections 3 and 6

Operation

The relay transmits the average value of two pressure signals

When the sum of the input pressures is rising, the output pressure also rises; conversely, falling input pressure produces falling output pressure. A variable pressure of 0 to 1.4 bar can also be supplied to connection 1; this provides maximum limitation of the output pressure, preventing it from ever exceeding the pressure at connection 1. There are two integrated restrictors (Ø 0.2 mm) for supplying the transducer.

Connection diagram

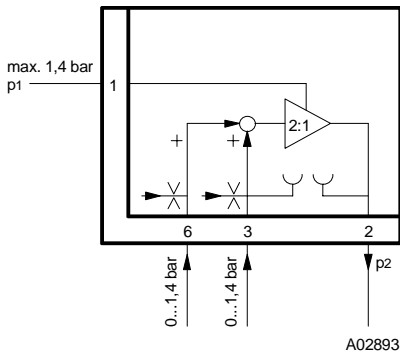

Dimension drawing

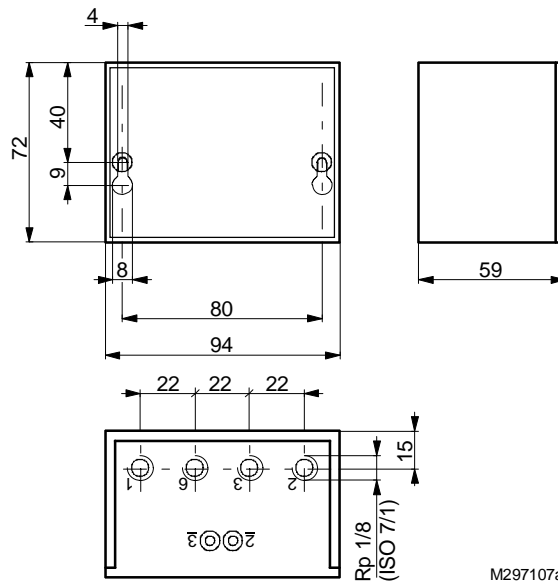

M297107a

Accessories

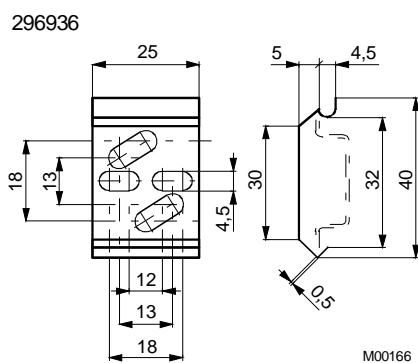

297091

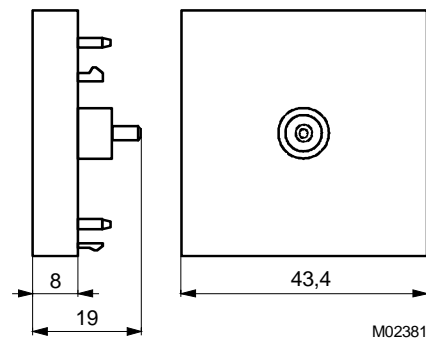

297113

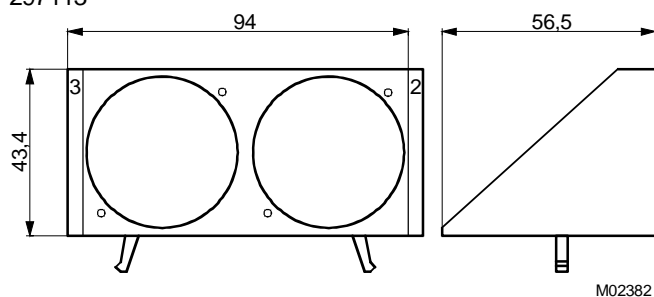

По вопросам продаж и поддержки обращайтесь:

Архангельск +7 (8182) 45-71-35	Калининград +7 (4012) 72-21-36	Новороссийск +7 (8617) 30-82-64	Сочи +7 (862) 279-22-65
Астана +7 (7172) 69-68-15	Калуга +7 (4842) 33-35-03	Новосибирск +7 (383) 235-95-48	Ставрополь +7 (8652) 57-76-63
Астрахань +7 (8512) 99-46-80	Кемерово +7 (3842) 21-56-70	Омск +7 (381) 299-16-70	Сургут +7 (3462) 77-96-35
Барнаул +7 (3852) 37-96-76	Киров +7 (8332) 20-58-70	Орел +7 (4862) 22-23-86	Сызрань +7 (8464) 33-50-64
Белгород +7 (4722) 20-58-80	Краснодар +7 (861) 238-86-59	Оренбург +7 (3532) 48-64-35	Сыктывкар +7 (8212) 28-83-02
Брянск +7 (4832) 32-17-25	Красноярск +7 (391) 989-82-67	Пенза +7 (8412) 23-52-98	Тверь +7 (4822) 39-50-56
Владивосток +7 (4232) 49-26-85	Курск +7 (4712) 23-80-45	Первоуральск +7 (3439) 26-01-18	Томск +7 (3822) 48-95-05
Владимир +7 (4922) 49-51-33_	Липецк +7 (4742) 20-01-75	Пермь +7 (342) 233-81-65	Тула +7 (4872) 44-05-30
Волгоград +7 (8442) 45-94-42	Магнитогорск +7 (3519) 51-02-81	Ростов-на-Дону +7 (863) 309-14-65	Тюмень +7 (3452) 56-94-75
Воронеж +7 (4732) 12-26-70	Москва +7 (499) 404-24-72	Рязань +7 (4912) 77-61-95	Ульяновск +7 (8422) 42-51-95
Екатеринбург +7 (343) 302-14-75	Мурманск +7 (8152) 65-52-70	Самара +7 (846) 219-28-25	Уфа +7 (347) 258-82-65
Иваново +7 (4932) 70-02-95	Наб.Челны +7 (8552) 91-01-32	Санкт-Петербург +7 (812) 660-57-09	Хабаровск +7 (421) 292-95-69
Ижевск +7 (3412) 20-90-75	Ниж.Новгород +7 (831) 200-34-65	Саранск +7 (8342) 22-95-16	Чебоксары +7 (8352) 28-50-89
Иркутск +7 (3952) 56-24-09	Нижневартовск +7 (3466) 48-22-23	Саратов +7 (845) 239-86-35	Челябинск +7 (351) 277-89-65
Йошкар-Ола +7 (8362) 38-66-61	Нижнекамск +7 (8555) 24-47-85	Смоленск +7 (4812) 51-55-32	Череповец +7 (8202) 49-07-18
Казань +7 (843) 207-19-05			Ярославль +7 (4852) 67-02-35

сайт: sauter.pro-solution.ru | эл. почта: sxr@pro-solution.ru
 телефон: 8 800 511 88 70