

## TUP 224 F901: Pneumatic sash sensor

### How energy efficiency is improved

Enables the demand-led control of the air volume in laboratory fume cupboards.

### Areas of application

Creation of VAV systems for fume cupboards, can be used especially in potentially explosive areas, in combination with the RLP 100 F123 pneumatic volume-flow controller.

### Features

- Continuous output signal is specified as command variable to the volume flow controller
- Installation preferably to be on counterweight of laboratory fume cupboard sash
- ATEX certification for use in Zone 1 potentially explosive areas
- Conformity tested as per EN 13463-1 and EN 1127-1 (Ex II 2 G T6)
- Compressed-air connections with Rp 1/8" female thread
- Long-term-stable stainless steel spring

### Technical description

- Supply pressure 1.3 bar  $\pm$  0.1
- Measuring ranges up to 2 m possible for free-standing fume cupboards
- Linearity 2%



T03494

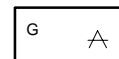

Y03489

Type	Measuring span <sup>1)</sup> m	Output pressure bar	Weight kg
<b>TUP 224 F901</b>	0,45...0,75	0,2...1,0	0,14
Supply pressure <sup>2)</sup> via external restrictor, $\varnothing$ 0,2 mm	1,3 bar $\pm$ 0,1	Permissible ambient temp.	0...55 °C
Air capacity, air consumption	33 l <sub>n</sub> /h	Connection diagram	<a href="#">A03488</a>
Linearity	2%	Dimension drawing	<a href="#">M00909</a>
Control action	B	Fitting instructions	<a href="#">MV 505210</a>

### Accessories

**0297832 001** Extension spring for man-sized (walk-in) fume cupboards with sliding-door movement of 2 m. Measuring span: 0,9...1,5 m.

- 1) Factory setting: 0,5 m; can be changed by varying the length of the spring (6 holes); measuring span: 0,9...1,5 m; with accessory no. 0297832 001
- 2) On the RLP volume-flow controllers, the restrictor ( $\varnothing$  0,14 mm) is fitted at input 6. For regulations on the quality of the air supply, especially at low ambient temperatures, see Section 60

### Operation

The transmitter – which works on the bleed-off force-balance principle – converts the path (i.e. the amount that the fume cupboard's sliding door is open) into a pneumatic output signal of 0,2...1,0 bar within its measuring range. Wear and tear has no effect on accuracy. The signal is fed as the command variable to the fume-cupboard exhaust-air controller. The air volume is adjusted within seconds in proportion to the amount of the opening. This decreases the risk of noxious gases escaping from the fume cupboard. The output pressure reacts in linear fashion to the opening. Control action is B: as the spring length  $\Delta l$  increases, the output pressure falls.

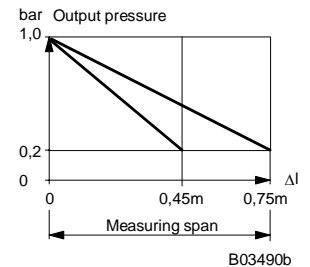

### По вопросам продаж и поддержки обращайтесь:

Волгоград +7 (8442) 45-94-42  
 Екатеринбург +7 (343) 302-14-75  
 Ижевск +7 (3412) 20-90-75  
 Казань +7 (843) 207-19-05

Краснодар +7 (861) 238-86-59  
 Красноярск +7 (391) 989-82-67  
 Москва +7 (499) 404-24-72  
 Ниж.Новгород +7 (831) 200-34-65

Новосибирск +7 (383) 235-95-48  
 Омск +7 (381) 299-16-70  
 Пермь +7 (342) 233-81-65  
 Ростов-на-Дону +7 (863) 309-14-65

Самара +7 (846) 219-28-25  
 Санкт-Петербург +7 (812) 660-57-09  
 Саратов +7 (845) 239-86-35  
 Сочи +7 (862) 279-22-65

**Fitting instructions**

Can be fitted in the following positions

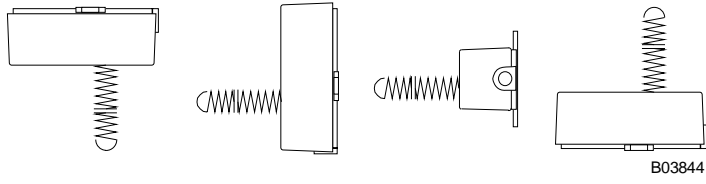

**Dimension drawing**

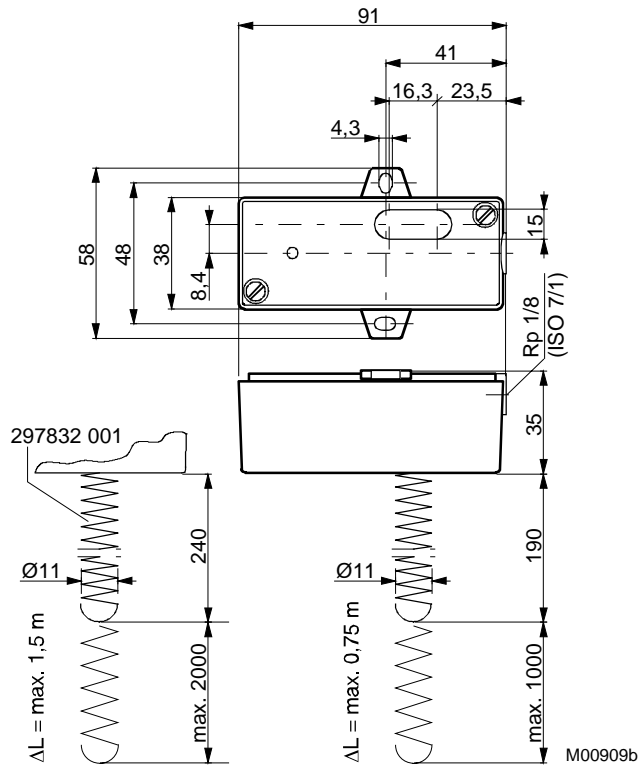

**Connection diagram**

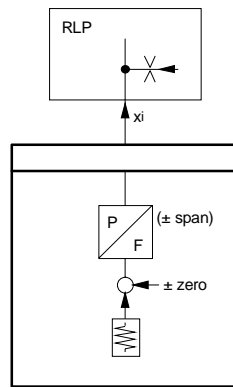

A03488

**Example of use**

Volume of return air controlled in proportion to the opening of the fume cupboard's sash; with sash sensor, alarm and operating units and adding relay.

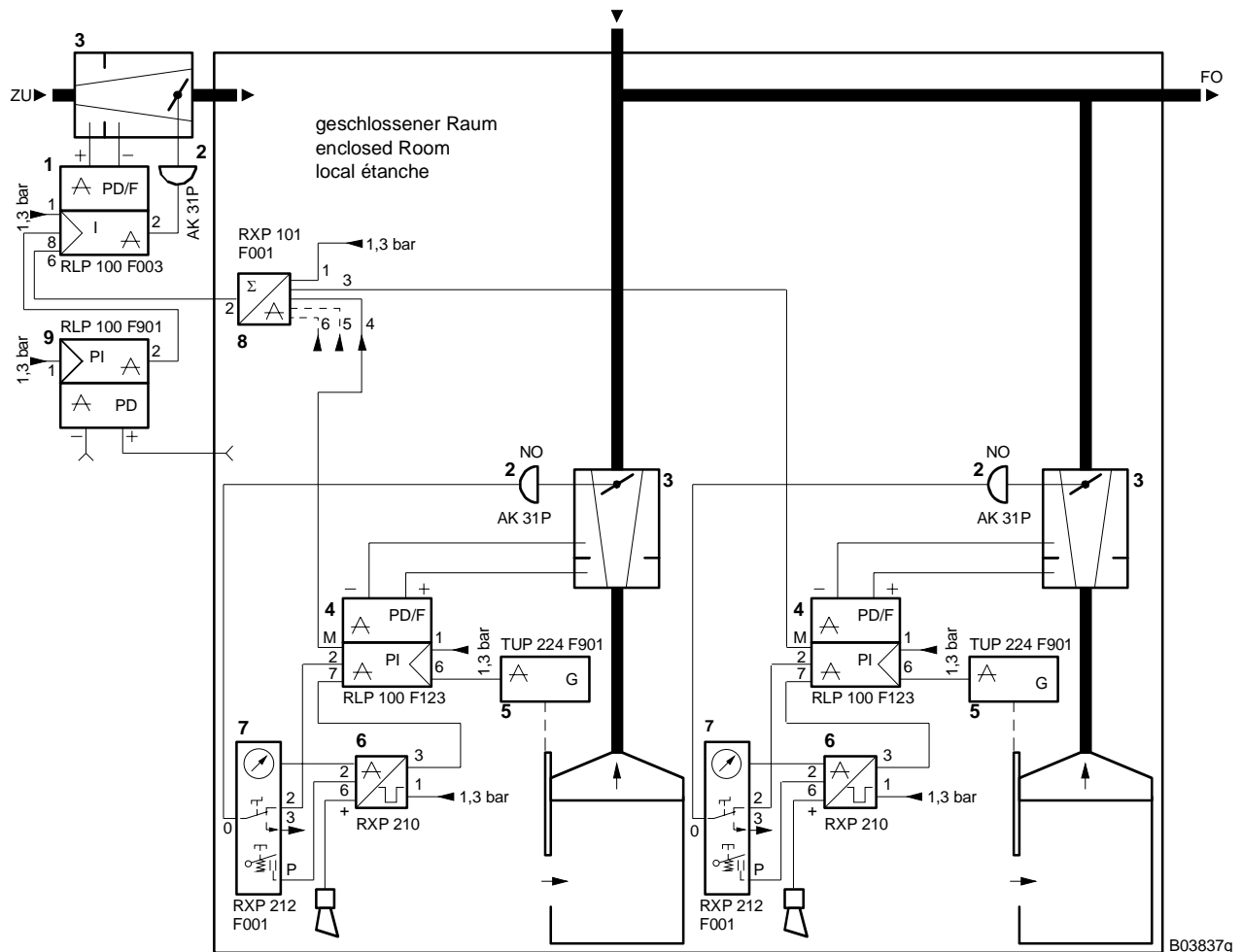

1	Volume-flow controller	7	Operating unit
2	Damper drive, NO	8	Volume-flow adding relay
3	Reducing box	9	Pressure controller
4	VAV return-air controller for fume cupboards	FO	EA (exhaust air)
5	Path-measuring transmitter	ZU	SA (supply air)
6	Alarm unit	NO	= normally open

**По вопросам продаж и поддержки обращайтесь:**

Волгоград +7 (8442) 45-94-42  
 Екатеринбург +7 (343) 302-14-75  
 Ижевск +7 (3412) 20-90-75  
 Казань +7 (843) 207-19-05

Краснодар +7 (861) 238-86-59  
 Красноярск +7 (391) 989-82-67  
 Москва +7 (499) 404-24-72  
 Ниж.Новгород +7 (831) 200-34-65

Новосибирск +7 (383) 235-95-48  
 Омск +7 (381) 299-16-70  
 Пермь +7 (342) 233-81-65  
 Ростов-на-Дону +7 (863) 309-14-65

Самара +7 (846) 219-28-25  
 Санкт-Петербург +7 (812) 660-57-09  
 Саратов +7 (845) 239-86-35  
 Сочи +7 (862) 279-22-65