



RXP 210: Air-volume alarm unit

Areas of application

Monitoring laboratory fume cupboard as per EN14175 in combination with an air-volume controller, type RLP100 F123, and the RXP 212 fume cupboard operating unit. Zone 1 potentially explosive areas.

Features

- Comparison of sash opening setpoint with actual value of air volume
- Feeding setpoint difference to alarm unit
- Acoustic alarm in the event that the actual value falls below or exceeds the specified value
- Thermoplastic housing suitable for wall or top-hat rail mounting (rail EN 60715)
- Compressed-air connections with Rp 1/8" female thread
- Low-pressure connections in form of stepped nipples for flexible plastic hose (internal Ø 4 and 6 mm)
- ATEX certification for use in Zone 1 potentially explosive areas
- Conformity tested as per EN 13463-1 and EN 1127-1 (Ex II 2 G T6)
- Complies with directive 97/23/EC Art. 3.3 on pressure equipment

Technical description

- Supply pressure 1.3 bar ± 0.1
- Response sensitivity 1%



Y03188

T05183

| Type | Description | Air capacity ³ | Air consumption ¹⁾ | Weight kg |
|-------------------------------|-----------------------------|---------------------------|-------------------------------|---------------------------|
| RXP 210 F001 | for monitoring the air flow | 180 l _n /h | 40 l _n /h | 0,2 |
| Supply pressure ²⁾ | 1,3 bar ± 0,1 | Response sensitivity | | 1% |
| Input pressures | | Perm. ambient temp. | | 0...55 °C |
| connector 3 | 0...1,3 bar | Type of protection | | IP 20 |
| connector 6 | 0,1...0,6 bar | Connection diagram | | A09890 |
| Output pressures | | Dimension drawing | | M297240 |
| connector 2 | 0...1,3 bar | Fitting instructions | | MV 505381 |
| connector + | approx. 1,0 bar | | | |

Accessories

- 0296936 000*** Bracket for rail EN 60715, 35 × 7,5 and 35 × 15
- 0297354 000*** Short screw-in connector R 1/8 for soft plastic tubing of internal dia. 4 mm, four pieces required
- 0297797 001*** Manometer with indication of deviation in air volume

*) Dimension drawing or wiring diagram are available under the same number

- 1) Extra air consumption when whistle is activated: 180 l_n/h
- 2) For regulations on the quality of the air supply, especially at low ambient temperatures, see section 60
- 3) Air output at connector +

Operation

Together with the RLP 100 F123 controller, the alarm unit monitors the air volume in the fume cupboard. The amount that the fume cupboard's sash is open is fed as a setpoint to the relevant VAV controller and compared to the actual value of the air volume. Any deviation is indicated visually in accordance with DIN 12924 (RXP 212 operating unit). In the event of a malfunction, an acoustic signal is emitted, e.g. whenever the actual value of the air volume is either smaller (min.) by > 8% \dot{V} or larger (max.) by 10% \dot{V} than the setpoint (factory setting). The 'min.' adjuster should not be set to a difference of > 8% \dot{V} . The whistle sounds after a delay of four to twelve seconds. It can be stopped by closing connector 6 (pressing the 'mute' button on the RXP 212 operating unit for about two seconds). When actual value again equals setpoint, the acoustic alarm is again ready for operation.

Technical information

Technical manual VAV 7 000621 003

По вопросам продаж и поддержки обращайтесь:

| | | | |
|---------------------------------|---------------------------------|-----------------------------------|------------------------------------|
| Волгоград +7 (8442) 45-94-42 | Краснодар +7 (861) 238-86-59 | Новосибирск +7 (383) 235-95-48 | Самара +7 (846) 219-28-25 |
| Екатеринбург +7 (343) 302-14-75 | Красноярск +7 (391) 989-82-67 | Омск +7 (381) 299-16-70 | Санкт-Петербург +7 (812) 660-57-09 |
| Ижевск +7 (3412) 20-90-75 | Москва +7 (499) 404-24-72 | Пермь +7 (342) 233-81-65 | Саратов +7 (845) 239-86-35 |
| Казань +7 (843) 207-19-05 | Ниж.Новгород +7 (831) 200-34-65 | Ростов-на-Дону +7 (863) 309-14-65 | Сочи +7 (862) 279-22-65 |

67.531/2 RXP 210

Connection diagram

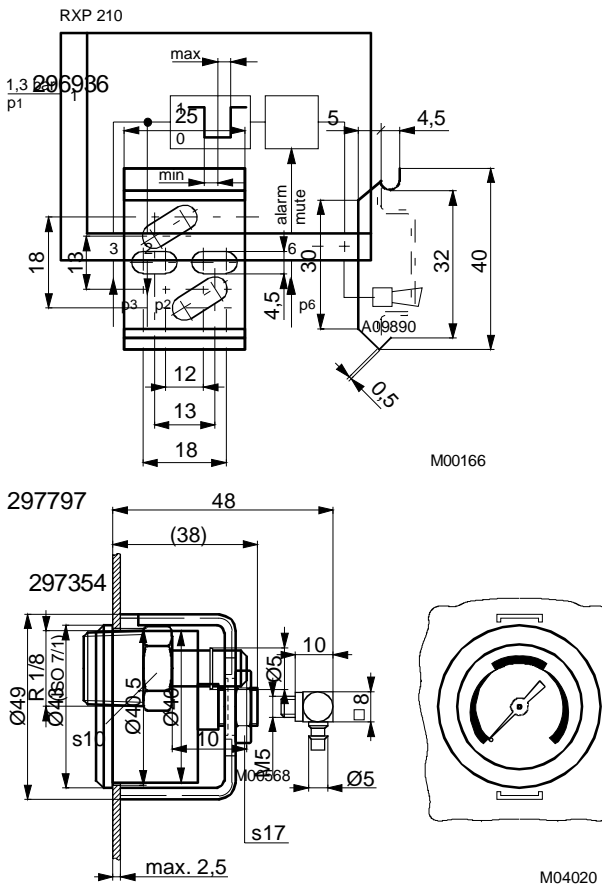

Dimension drawing

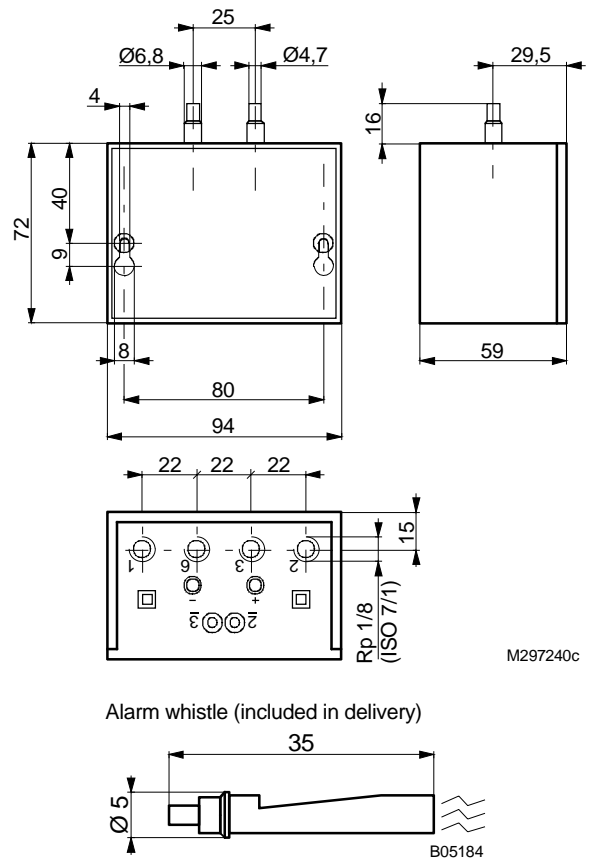

Example of use

Volume of return air controlled in proportion to the opening of the fume cupboard's sash; with sash sensor, alarm unit and operating unit; taking the room temperature into account.

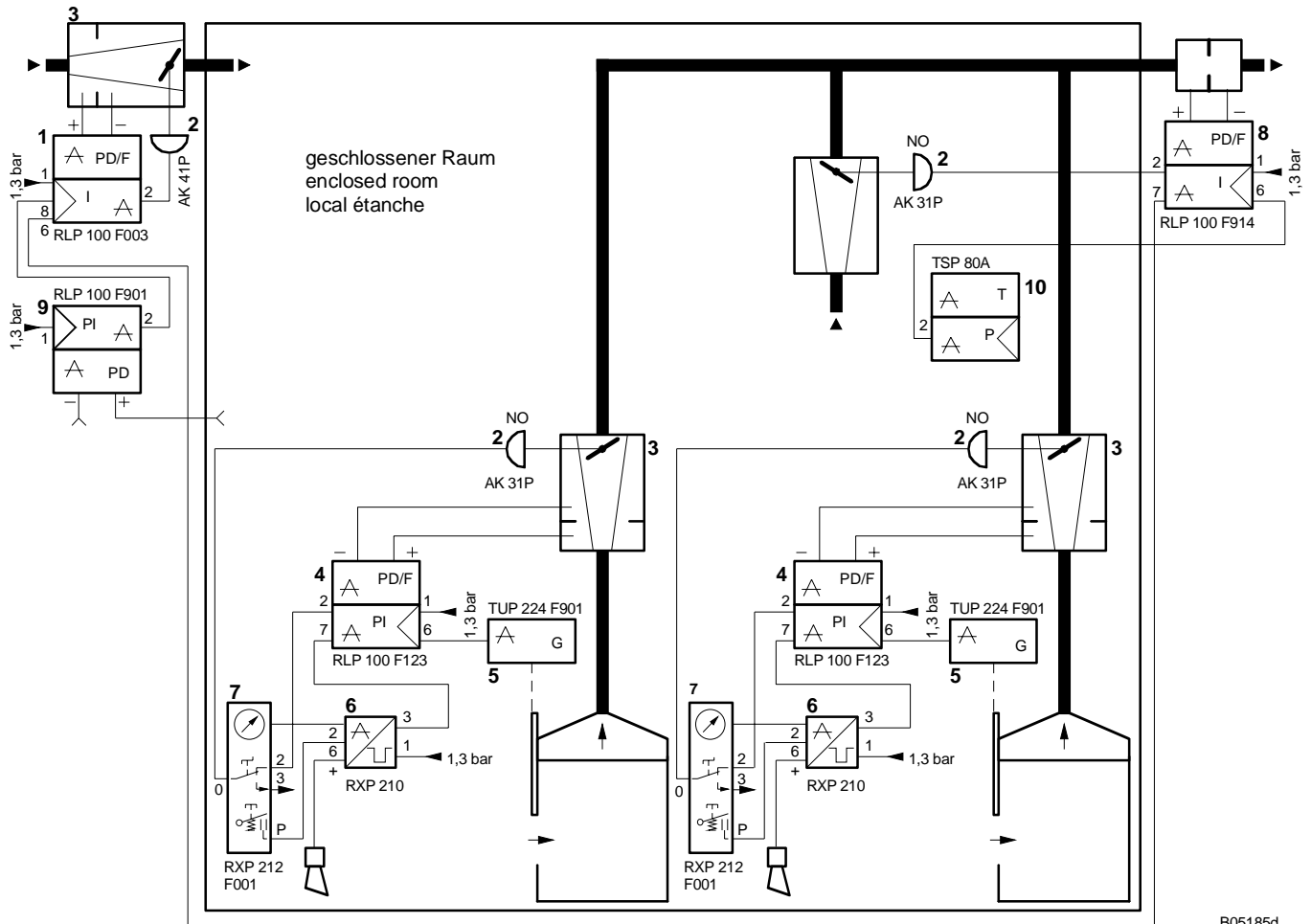

B05185d

| | | | |
|---|--|----|---|
| 1 | Volume-flow controller | 8 | Room return-air controller for aggressive gases |
| 2 | Damper drive, NO | 9 | Pressure controller |
| 3 | Reducing box | 10 | Room-temperature controller |
| 4 | VAV return-air controller for fume cupboards | 11 | Manometer 0297797 |
| 5 | Sash sensor | 12 | Mute button, alarm reset |
| 6 | Alarm unit | | Micro-valve S0-3-PK-3-B |
| 7 | Operating unit | | Pressure switch AT-06-B (made by Festo) |
| | | | NO = normally open |

По вопросам продаж и поддержки обращайтесь:

Волгоград +7 (8442) 45-94-42
 Екатеринбург +7 (343) 302-14-75
 Ижевск +7 (3412) 20-90-75
 Казань +7 (843) 207-19-05

Краснодар +7 (861) 238-86-59
 Красноярск +7 (391) 989-82-67
 Москва +7 (499) 404-24-72
 Ниж.Новгород +7 (831) 200-34-65

Новосибирск +7 (383) 235-95-48
 Омск +7 (381) 299-16-70
 Пермь +7 (342) 233-81-65
 Ростов-на-Дону +7 (863) 309-14-65

Самара +7 (846) 219-28-25
 Санкт-Петербург +7 (812) 660-57-09
 Саратов +7 (845) 239-86-35
 Сочи +7 (862) 279-22-65