

RCP 10, 11: PI-controller

How energy efficiency is improved

Enables the implementation of individually optimised controls for maximum efficiency in pneumatic installations.

Areas of application

Pneumatic control in ventilation and air-conditioning equipment of temperature, pressure, pressure differential, humidity and flow rate in combination with appropriate transducers.

Features

- PI fixed-value controller
- PI fixed-value/schedule controller
- Controllers can be used universally for the most varied of applications
- Housing, rack and front doors made of thermoplastic
- Suitable for wall or panel mounting
- Functional description and commissioning help inserted in front door
- Front panel with adjusters and 3 covered recesses for plug-in pressure gauge (XMP) making commissioning easier
- Setpoint adjuster X_S adjustable manually with scales for all Centair ranges
- All settings very easy to make with coin and % scale
- M4 measuring connections, control action adjustable (delivered with control action B)
- Rp 1/8" female thread
- Complies with directive 97/23/EC Art. 3.3 on pressure equipment

Technical description

- Supply pressure 1.3 bar ± 0.1
- Easily accessible adjusters for X_S (setpoint), X_{P4} (P range), T_n (reset time), E (influence) and FF (schedule start point)
- Inputs for:
 - remote setpoint adjustment
 - controlled variable
 - command variable
- Outputs for:
 - output pressure for dampers or valve actuator



T03082

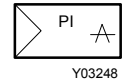

Y03248

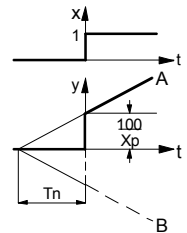

PI-controller

B02214

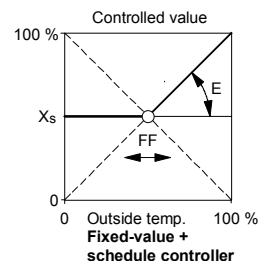

Fixed-value + schedule controller

B03257

Type	Description	Air capacity l _n /h	Air consumption ¹⁾ l _n /h	Weight kg
RCP 10 F001	fixed-value PI-controller	400	30	0,7
RCP 11 F001	fixed-value/schedule PI controller	400	30	0,7
RCP 10:		RCP 11:		
Setpoint X _S	0...100%	Setpoint X _S	0...100%	
Remote adjust. of setpoint	0...100%	Remote adjustment of setpoint	0...100%	
P-band X _{P4}	0...100%	P-band X _{P4}	0...100%	
Reset time T _n	1...15 min	Reset time T _n	1...15 min	
		Shift starting point FF	0...100%	
		Influence E	0,25...3	
Supply pressure ²⁾	1,3 bar ± 0,1	Connection diagram, RCP 10	A02690	
Input pressures	0,2...1,0 bar	Connection diagram, RCP 11	A02691	
Output pressures	0,2...1,0 bar	Dimension drawing	M297100	
Permissible amb. temp.	0...55 °C	Fitting instructions	MV 3246	

По вопросам продаж и поддержки обращайтесь:

Волгоград +7 (8442) 45-94-42
 Екатеринбург +7 (343) 302-14-75
 Ижевск +7 (3412) 20-90-75
 Казань +7 (843) 207-19-05

Краснодар +7 (861) 238-86-59
 Красноярск +7 (391) 989-82-67
 Москва +7 (499) 404-24-72
 Ниж.Новгород +7 (831) 200-34-65

Новосибирск +7 (383) 235-95-48
 Омск +7 (381) 299-16-70
 Пермь +7 (342) 233-81-65
 Ростов-на-Дону +7 (863) 309-14-65

Самара +7 (846) 219-28-25
 Санкт-Петербург +7 (812) 660-57-09
 Саратов +7 (845) 239-86-35
 Сочи +7 (862) 279-22-65

Operation

RCP 10 and RCP 11

The transducer at connection 4 converts the control variable into the pneumatic standard signal 0,2...1,0 bar (equivalent to 0...100%) within its measuring range. This actual-value signal x_{i4} is compared with the fixed setpoint X_s . If there is control deviation, the output pressure y is adjusted until the actual value is equal to the setpoint (PI-control). With a pressure of 0,2...1,0 bar at input 6, the setpoint can be set remotely from 0...100%. The internal setpoint setting then functions as a minimum limitation.

A restrictor (\varnothing 0,2 mm) for supplying the transducer is fitted at connection 4. The signals from the transducer and the output pressure can be checked via the M4 measuring connection or shown via the manometer.

RCP 11: additional functions

The transducer at connection 5 converts the command variable (e.g. outside temperature) into the pneumatic standard signal 0,2...1,0 bar (equivalent to 0...100%). This signal (x_{i5}) is fed to the command circuit which, together with the setting parameters FF and E, creates a program for the setpoint shift of the following PI-controller. The characteristic for the influence E can be placed in any of the four quadrants.

Because the outside temperature is often fed to more than one controller, the transducer at connection 5 must be supplied by a separate (\varnothing 0,2 mm) restrictor.

Additional details

RCP 10: Front plate with adjusters for setpoint, P-band and reset time.

RCP 11: Front plate with adjusters for setpoint, P-band, reset time, influence and shift starting point.

Additional information on accessories

0297103 000	Additional bag of eight alternative scales	
	5...35 °C	20...90 %rh
	-20...40 °C	0...5 mbar
	0...120 °C	5...10 mbar
	80...200 °C	10...15 mbar

Technical information

Technical manual: *centair* system 304991 003

Connection diagrams

RCP 10

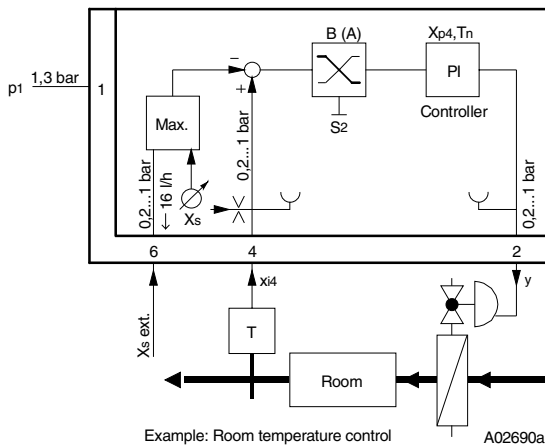

RCP 11

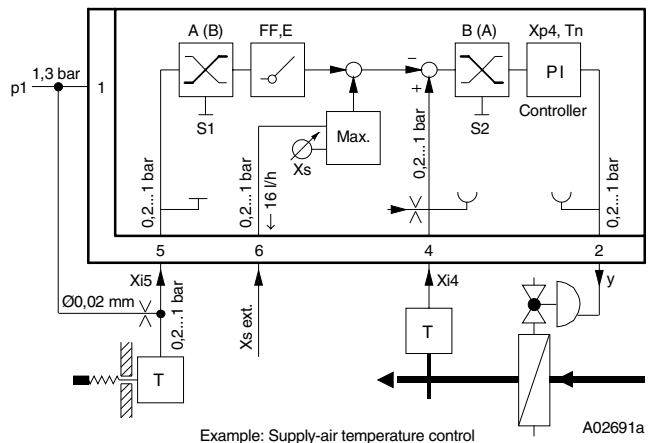

- 1 Supply pressure
- 2 Output pressure
- 4 Actual value for PI-controller
- 5 Command variable for fixed-value + schedule
- 6 Remote setpoint adjustment

- T_n Reset time
- X_s Variable setpoint
- X_{p4} P-band for PI-controller
- FF Shift starting point for fixed-value + schedule
- E Influence

- x_{i4} Control variable
- x_{i5} Command variable
- y Output pressure
- S1 Control action for fixed-value + schedule
- S2 Control action for controller

Dimension drawing

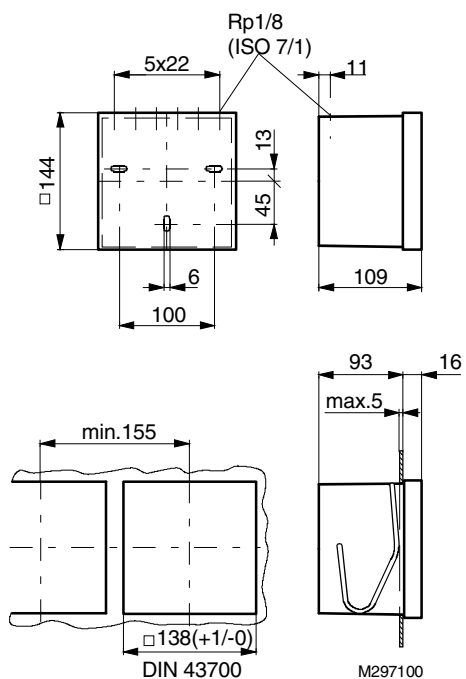

По вопросам продаж и поддержки обращайтесь:

Волгоград +7 (8442) 45-94-42
 Екатеринбург +7 (343) 302-14-75
 Ижевск +7 (3412) 20-90-75
 Казань +7 (843) 207-19-05

Краснодар +7 (861) 238-86-59
 Красноярск +7 (391) 989-82-67
 Москва +7 (499) 404-24-72
 Ниж.Новгород +7 (831) 200-34-65

Новосибирск +7 (383) 235-95-48
 Омск +7 (381) 299-16-70
 Пермь +7 (342) 233-81-65
 Ростов-на-Дону +7 (863) 309-14-65

Самара +7 (846) 219-28-25
 Санкт-Петербург +7 (812) 660-57-09
 Саратов +7 (845) 239-86-35
 Сочи +7 (862) 279-22-65