

RPP: P-controller

How energy efficiency is improved

Enables the implementation of individually optimised controls for maximum efficiency in pneumatic installations.

Areas of application

Pneumatic control of temperature, pressure, differential pressure, humidity and flow rate in combination with appropriate transducer.

Features

- P fixed-value controller for universal use
- Application as switching relay (On/Off controller) possible
- Controller front panel is printed with circuit diagram for rapid identification of function
- Thermoplastic housing suitable for wall or top-hat rail mounting
- Compressed-air connections with Rp 1/8" female thread
- Complies with directive 97/23/EC Art. 3.3 on pressure equipment

Technical description

- Supply pressure 1.3 bar \pm 0.1
- Easily accessible adjusters for X_S (setpoint), X_P (P range), zero point
- Inputs for:
 - actual value
 - remote setpoint adjustment
- Outputs for:
 - output pressure for damper drive

Type	Description	Air capacity l/h	Air consumption ¹⁾ l/h	Weight kg
RPP 20 F001	P-fixed-value controller ²⁾	400	40	0,2
Supply pressure ³⁾	1,3 bar \pm 0,1	Zero point		0...100%
Input pressures	0,2...1,0 bar	Permissible amb. temp.		0...55 °C
Output pressures	0,2...1,0 bar	Connection diagram		A02886
Setpoint X _S	0...100%	Dimension drawing		M297107
Remote adjustment of setpoint	0...100%	Fitting instructions		MV 3248
P-band X _P	0...100%			

Accessories

- 0296936 000*** Bracket for rail EN 50022, 35 \times 7,5 and 35 \times 15
- 0297103 000** Additional bag of scales with 8 different scales according to the transducer used.
- 0297113 000*** Manometer bracket for two XMP manometers, including fixing material, MV 3255
- 0297091 000*** Cover for unused manometer apertures when 0297113 is used.
- 0297133 000** Universal scales for setpoint adjuster X_S, gradation 120, 80/160, 50/100, 30/60

*) Dimension drawing or wiring diagram are available under the same number

- 1) Without transducer; air consumption for transducer connection 3 is 33 l/h more.
- 2) Can be used as a switching relay (on/off controller) by transposing two tubes.
- 3) See Section 60 on regulations concerning the quality of supply air, especially at low ambient temperatures.

Operation

The transducer at connection 3 converts the control variable into the pneumatic standard signal 0,2...1,0 bar (equivalent to 0...100%) within its measuring range. This actual-value signal x_{13} is compared with the fixed setpoint X_S. If there is control deviation, the output pressure changes depending on the set P-band X_{P3} (P-control). When the actual value is equal to the setpoint ($x_{13} = X_S$), the output pressure always assumes the value zero (0,6 bar).

With a pressure of 0,2...1,0 bar at input 6, the setpoint can be set remotely from 0...100%. The internal setpoint setting then functions as a minimum limitation.

A restrictor (\varnothing 0,2 mm) for supplying the transducer is fitted at connection 3. The signals from both the transducer and the output pressure can be checked via the M4 measuring connection or shown via the manometer.



T03050

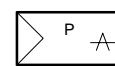

Y03247

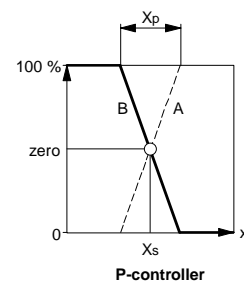

B03811

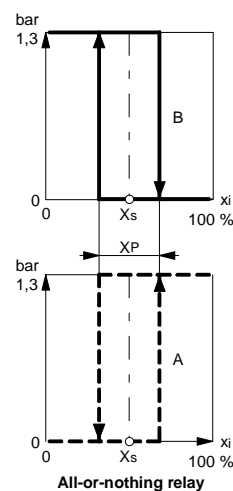

B03847

По вопросам продаж и поддержки обращайтесь:

Волгоград +7 (8442) 45-94-42
Екатеринбург +7 (343) 302-14-75
Ижевск +7 (3412) 20-90-75
Казань +7 (843) 207-19-05

Краснодар +7 (861) 238-86-59
Красноярск +7 (391) 989-82-67
Москва +7 (499) 404-24-72
Ниж.Новгород +7 (831) 200-34-65

Новосибирск +7 (383) 235-95-48
Омск +7 (381) 299-16-70
Пермь +7 (342) 233-81-65
Ростов-на-Дону +7 (863) 309-14-65

Самара +7 (846) 219-28-25
Санкт-Петербург +7 (812) 660-57-09
Саратов +7 (845) 239-86-35
Сочи +7 (862) 279-22-65

The switching difference can be varied between approx. 0,02 and 1,3 bar by using the adjuster X_p (0...100%). The set value in percentage refers to the supply pressure of 1,3 bar plus the intrinsic switching difference of 0,02 bar.

Example $X_p = 10\%$: switching difference = 10% of 1,3 + 0,02 = 0,13 + 0,02 = 0,15 bar

Additional information on accessories

0297103 000 Additional bag of eight alternative scales

5...35 °C	20...90 %hr
-20...40 °C	0...5 mbar
0...120 °C	5...10 mbar
80...200 °C	10...15 mbar

Technical information

Technical manual: *centair* system 304991 003

Connection diagram

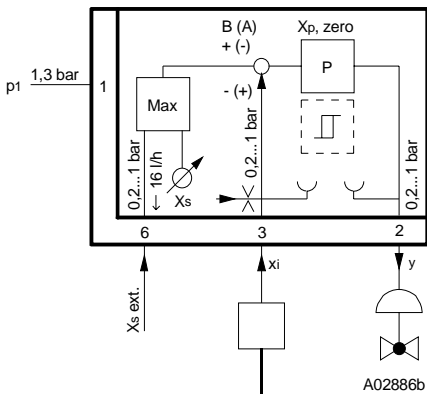

1	Supply pressure	X_S	Variable setpoint
2	Output pressure	X_P	P-band
3	Actual-value input	zero	zero point
6	Remote setpoint adjustment	x_i	Control variable
		y	Output pressure

Dimension drawing

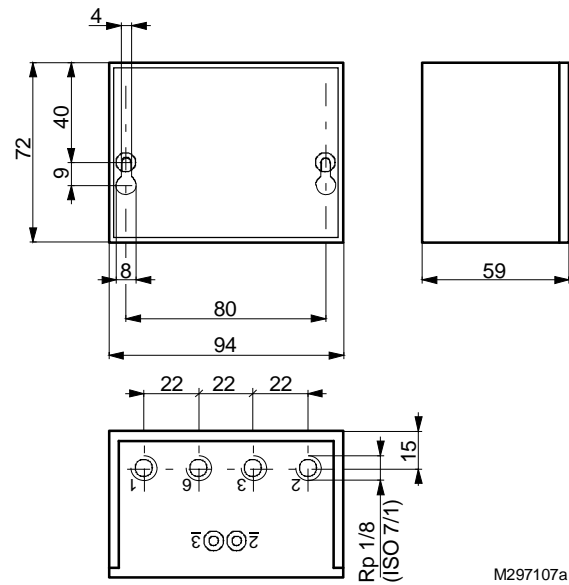

M297107a

Accessories

296936

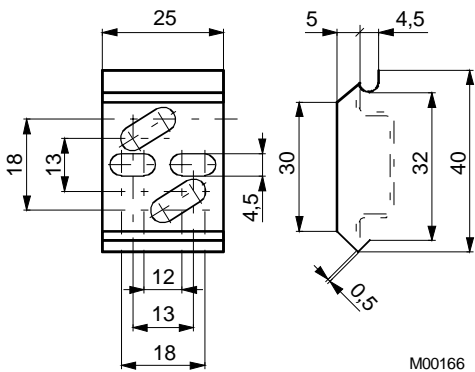

297091

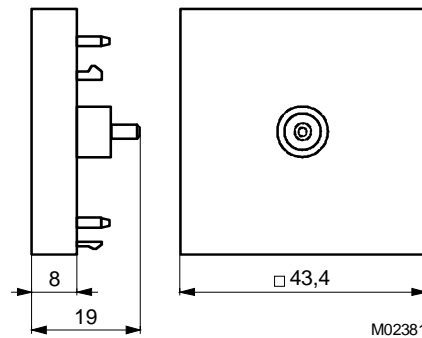

По вопросам продаж и поддержки обращайтесь:

Волгоград +7 (8442) 45-94-42
 Екатеринбург +7 (343) 302-14-75
 Ижевск +7 (3412) 20-90-75
 Казань +7 (843) 207-19-05

Краснодар +7 (861) 238-86-59
 Красноярск +7 (391) 989-82-67
 Москва +7 (499) 404-24-72
 Ниж.Новгород +7 (831) 200-34-65

Новосибирск +7 (383) 235-95-48
 Омск +7 (381) 299-16-70
 Пермь +7 (342) 233-81-65
 Ростов-на-Дону +7 (863) 309-14-65

Самара +7 (846) 219-28-25
 Санкт-Петербург +7 (812) 660-57-09
 Саратов +7 (845) 239-86-35
 Сочи +7 (862) 279-22-65