

TSUP: Room-temperature transducer

How energy efficiency is improved

Accurate recording of room temperature in pneumatic installations for optimal control of HVAC systems.

Areas of application

Continuous pneumatic measurement and/or control of room temperature in combination with pneumatic control equipment (Centair).

Features

- Part of the Centair family of systems
- Conversion of room temperature into a standard 0.2 to 1.0 bar pneumatic signal
- Lid in thermoplastic with grey/white frame (RAL 9002) and pure-white front panel (RAL 9010)
- Compressed-air connection on plug nipple for flexible plastic hose int. \varnothing 4 mm
- Complies with directive 97/23/EC Art. 3.3 on pressure equipment

Technical description

- Supply pressure 1.3 bar \pm 0.1
- Nozzle/ball system
- Linearity of output signal < 2%

Type	Measuring range °C	Output pressure bar	Weight kg
TSUP 1 F001	5...35	0,2...1,0	0,17
Supply pressure 1)		Permissible ambient temp.	0...70 °C
via external restrictor \varnothing 0,2 mm	1,3 \pm 0,1 bar	Connection diagram	A02781
Air capacity, air consumption	33 l _n /h	Dimension drawing	M303048
Linearity	< 2%	Fitting instructions	MV 23153
Time constant (0,2 m/s)	5 min		

Accessories

- 0296218 000*** Buckle-proof adaptor for push-on fitting.
0296990 000* Buckle-proof adaptor for screw-type fitting; see MV 7322.
0303124 000* Recessed junction box.
0310315 000* Surface junction box.

*) Dimension drawing or wiring diagram are available under the same number

1) In the RCP and RPP 20 controllers, the restrictors (\varnothing 0,2 mm) are fitted at inputs 3 and 4.
See Section 60 on regulations concerning the quality of supply air, especially at low ambient temperatures.

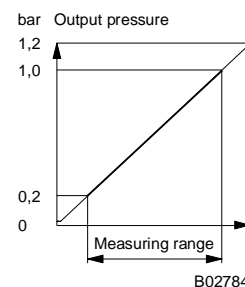
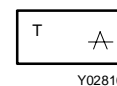

Operation

As the temperature rises, the bimetal strip bends and exerts a corresponding force on the nozzle-ball system. This converts the force into a pressure change. The output pressure increases as the temperature rises.

Technical information

Technical manual: *centair* system 304991 003

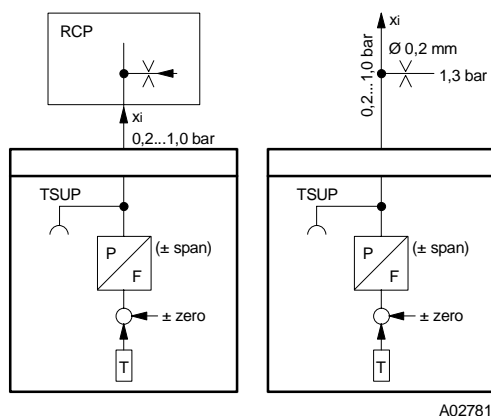

A02781

По вопросам продаж и поддержки обращайтесь:

Волгоград +7 (8442) 45-94-42
 Екатеринбург +7 (343) 302-14-75
 Ижевск +7 (3412) 20-90-75
 Казань +7 (843) 207-19-05

Краснодар +7 (861) 238-86-59
 Красноярск +7 (391) 989-82-67
 Москва +7 (499) 404-24-72
 Ниж.Новгород +7 (831) 200-34-65

Новосибирск +7 (383) 235-95-48
 Омск +7 (381) 299-16-70
 Пермь +7 (342) 233-81-65
 Ростов-на-Дону +7 (863) 309-14-65

Самара +7 (846) 219-28-25
 Санкт-Петербург +7 (812) 660-57-09
 Саратов +7 (845) 239-86-35
 Сочи +7 (862) 279-22-65

Dimension drawing

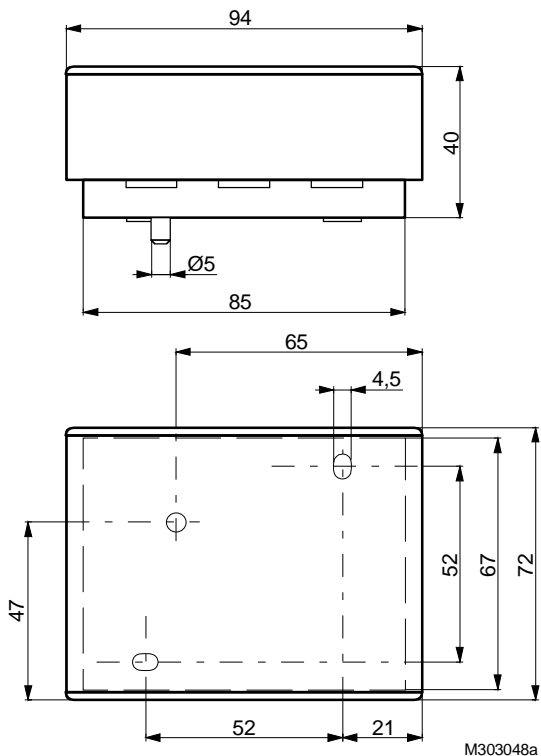

Accessories

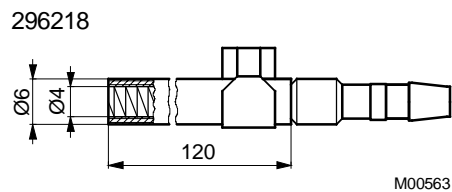
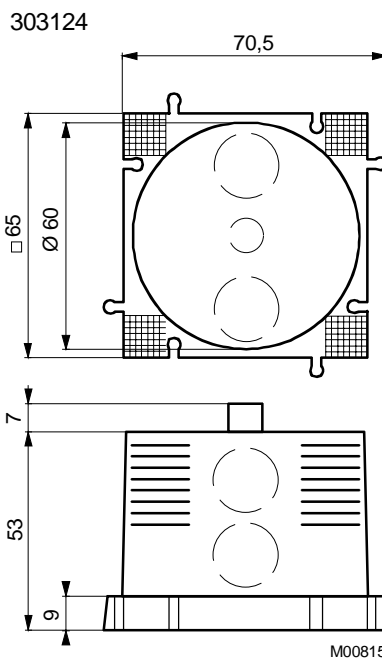
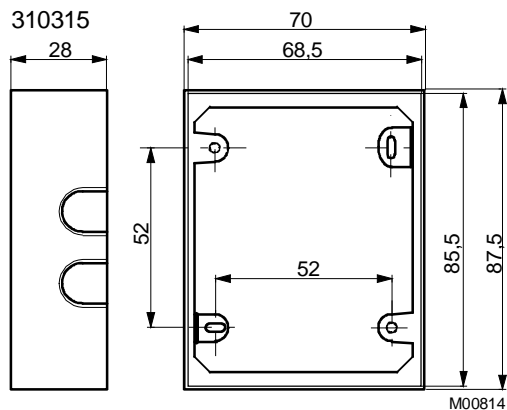

По вопросам продаж и поддержки обращайтесь:

Волгоград +7 (8442) 45-94-42
 Екатеринбург +7 (343) 302-14-75
 Ижевск +7 (3412) 20-90-75
 Казань +7 (843) 207-19-05

Краснодар +7 (861) 238-86-59
 Красноярск +7 (391) 989-82-67
 Москва +7 (499) 404-24-72
 Ниж.Новгород +7 (831) 200-34-65

Новосибирск +7 (383) 235-95-48
 Омск +7 (381) 299-16-70
 Пермь +7 (342) 233-81-65
 Ростов-на-Дону +7 (863) 309-14-65

Самара +7 (846) 219-28-25
 Санкт-Петербург +7 (812) 660-57-09
 Саратов +7 (845) 239-86-35
 Сочи +7 (862) 279-22-65