

TWUP: Outdoor-temperature transducer

How energy efficiency is improved

Accurate recording of temperature in pneumatic installations for optimal control of HVAC systems.

Areas of application

Pneumatic measurement and/or control of outside temperature in combination with pneumatic control equipment (Centair).

Features

- Part of the Centair family of systems
- Capillary tube and cartridge filled with expansion fluid
- Conversion of temperature into a standard 0.2 to 1.0 bar pneumatic signal

Technical description

- Supply pressure 1.3 bar \pm 0.1
- Nozzle/ball system
- Linearity of output signal < 2%

Type	Measuring range °C	Cartridge ø mm	Capillary tube m	Sensor temp. °C	Weight kg
TWUP 210 F001	-20...40	9	1,5	-25...70	0,24
TWUP 220 F001	5...35	9	1,5	-25...70	0,24

Supply pressure 1)			Time constant in air	
via external restrictor ø0,2 mm	1,3 \pm 0,1 bar		0,5 m/s	3,2 min
Output pressure	0,2...1,0 bar		3,0 m/s	1,6 min
Air capacity, air consumption	33 l _n /h			
Linearity	< 2%		Influence of temp. at instrument head	0,1 K/K
			Permissible ambient temp.	0...70 °C
Time constant in water			Connection diagram	A02781
without sheath	12 s		Dimension drawing	M297634
with sheath	70 s		Fitting instructions	MV 23212
sheath plus heat-conducting paste	25 s			

Accessories

- 0364440 120*** LW15 pocket of brass, 120mm, with R½ thread; 16bar)
0364258 120* LW15 pocket of inox, 120mm, with G½ thread; 25bar; bushing (0364140) also required 2)
0364140 000* Support to relieve pressure on capillary tube in sheath
0303212 000* Sensor holder for duct mounting

*) Dimension drawing or wiring diagram are available under the same number

- 1) In the RCP and RPP 20 controllers, the restrictors (ø0,2 mm) are fitted at inputs 3 and 4. See Section 60 on regulations concerning the quality of supply air, especially at low ambient temperatures.
 2) For further technical details, see page 29.01 or 29.001

Operation

The expansion fluid in the cartridge expands when exposed to heat and exerts a proportional pressure on the diaphragm box. This is converted by spring converter into a force acting on the force-comparison lever. The bleed-off nozzle-ball system converts this force into a corresponding pressure change. The output pressure increases as the temperature rises.

Engineering and fitting instructions

The positional effect can easily be negated by making the necessary adjustment of the screw in the centre of the diaphragm box. Since the measuring span is unaffected by either fitting or use, the tension of the spring converter should not be altered.



T03472

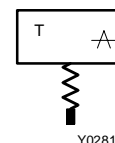

Y02813

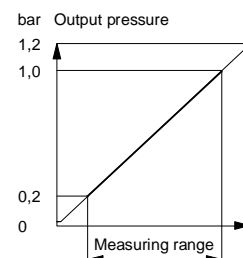

B02784

По вопросам продаж и поддержки обращайтесь:

Волгоград +7 (8442) 45-94-42
 Екатеринбург +7 (343) 302-14-75
 Ижевск +7 (3412) 20-90-75
 Казань +7 (843) 207-19-05

Краснодар +7 (861) 238-86-59
 Красноярск +7 (391) 989-82-67
 Москва +7 (499) 404-24-72
 Ниж.Новгород +7 (831) 200-34-65

Новосибирск +7 (383) 235-95-48
 Омск +7 (381) 299-16-70
 Пермь +7 (342) 233-81-65
 Ростов-на-Дону +7 (863) 309-14-65

Самара +7 (846) 219-28-25
 Санкт-Петербург +7 (812) 660-57-09
 Саратов +7 (845) 239-86-35
 Сочи +7 (862) 279-22-65

Permissible fitting positions

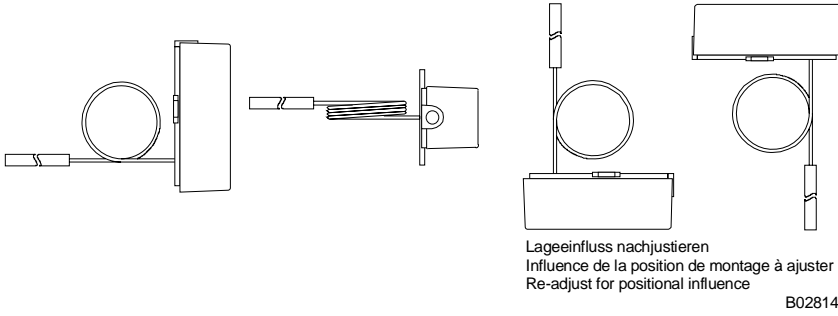

Technical information

Technical manual: *centair system* 304991 003

Connection diagram

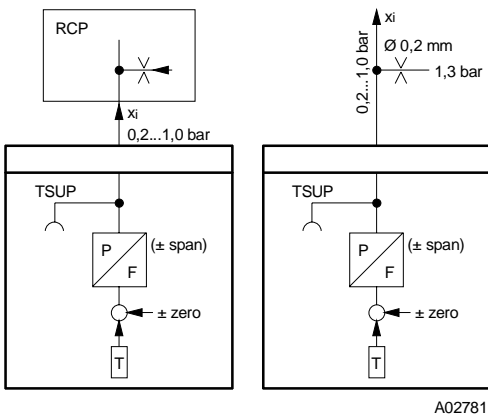

Accessories

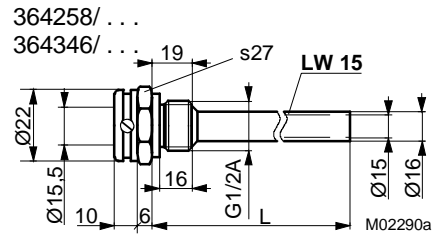
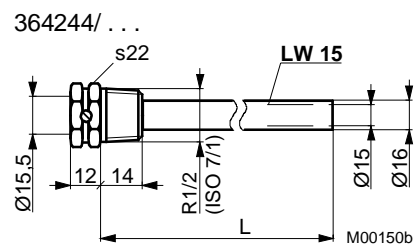

Dimension drawing

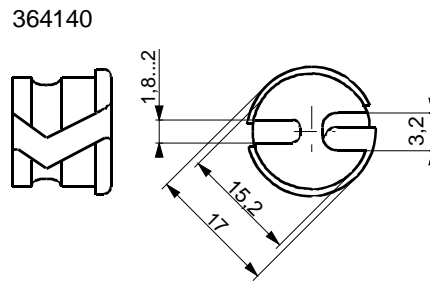
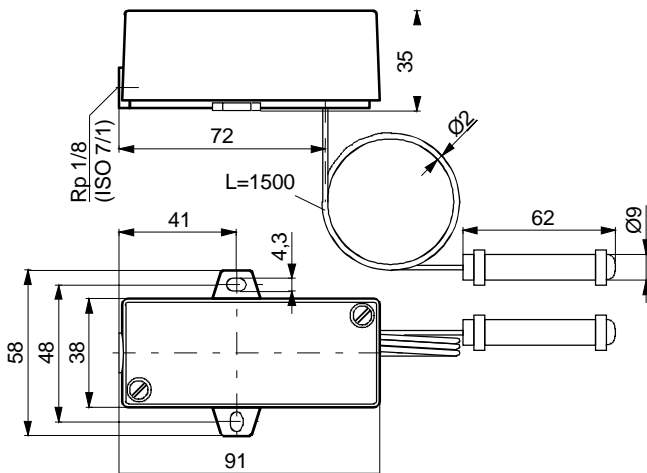

По вопросам продаж и поддержки обращайтесь:

Волгоград +7 (8442) 45-94-42
 Екатеринбург +7 (343) 302-14-75
 Ижевск +7 (3412) 20-90-75
 Казань +7 (843) 207-19-05

Краснодар +7 (861) 238-86-59
 Красноярск +7 (391) 989-82-67
 Москва +7 (499) 404-24-72
 Ниж.Новгород +7 (831) 200-34-65

Новосибирск +7 (383) 235-95-48
 Омск +7 (381) 299-16-70
 Пермь +7 (342) 233-81-65
 Ростов-на-Дону +7 (863) 309-14-65

Самара +7 (846) 219-28-25
 Санкт-Петербург +7 (812) 660-57-09
 Саратов +7 (845) 239-86-35
 Сочи +7 (862) 279-22-65