

XRP: Pneumatic relay, plug-in type

Areas of application

Conversion and/or isolation of pneumatic pressure signals, e.g. in the case of command variables and small drives.

Features

- Auxiliary relay with low air capacity for conversion and/or isolation of pneumatic pressure signals
- Can be used as interface, reversing, sequence or reversing/sequence relay
- Complies with directive 97/23/EC Art. 3.3 on pressure equipment

Technical description

- Bleed-off nozzle/deflector system

Type	Description	Input bar	Output bar	Weight g
XRP 101 F001	interface relay	0,2...1,0	0,2...1,0	22
XRP 102 F001	reversing relay	0,2...1,0	1,0...0,2	50
XRP 103 F001	sequence relay ²⁾	0,6...1,0	0,2...1,0	10
XRP 104 F001	sequence-reversing relay ³⁾	0,2...0,6	1,0...0,2	50

Supply pressure ¹⁾	1,3 ± 0,1 bar	Documentation	Connection	Dimensions	Fitting
Air output, air consumption	33 l _n /h	XRP 101	A03940	M00876	MV 505088
Reversing relay 297600	19 l _n /h	XRP 102	A03941	M00132	MV 7334
Max. air exhaust	50 l _n /h	XRP 103	A03940	M00131	MV 7333
Perm. input pressure	0...1,4 bar	XRP 104	A03940	M00132	MV 7335
Perm. output pressure	0...1,4 bar				
Perm. ambient temp.	0...55 °C				

Accessories

- 0296936 000** Bracket for rail EN 60715, 35 × 7,5 and 35 × 15 (not for XRP 103)
0296937 000 Bracket for rail C, EN 60715-C20 (not for XRP 103)

- 1) Supply via external restrictor of Ø 0,2 mm (reversing relay 297600: internal restrictor of Ø 0,2 mm). When used in conjunction with RLP controllers, the restrictor and the air consumption do not apply. Up to three RLP controllers can be connected to each relay. See Section 60 on regulations concerning the quality of supply air, especially at low ambient temperatures.
 2) Starting point can be set anywhere between 0,2 and 0,6 bar; factory setting is 0,6 bar.
 3) Starting point can be set anywhere between 0,6 and 1,0 bar; factory setting is 0,6 bar.

Operation

Interface relay

For the decoupling of pneumatic signals or for the load-free transmission of a weak signal. The standard pressure signal of 0,2...1,0 bar at input 3 is fed at a ratio of 1:1 to output 2.

Reversing relay

For reversing the control action of the command variable. The standard pressure signal of 0,2...1,0 bar at input 3 is inverted and fed to output 2 as 1,0...0,2 bar.

Sequence relay

For splitting the standard pressure signal into two sequence ranges. The signal of 0,2...1,0 bar at input 3 is fed with double amplification to output 2 when it exceeds 0,6 bar. The starting point can be set between 0,2 and 0,6 bar.

Sequence-reversing relay

For splitting and reversing the standard pressure signal into two sequence ranges. The standard pressure signal of 0,2...1,0 bar at input 3 is inverted and, between 0,2 and 0,6 bar, is converted into an output pressure of 1,0...0,2 bar. The starting point can be set between 0,6 and 1,0 bar.

Engineering and fitting notes

Sequence relay: can be plugged straight into the pneumatic line.

Reversing, interface and sequence-reversing relays: can be plugged straight into the pneumatic line or fitted onto either walls or rails. See *Accessories*.



1:1

Y07575



Y07576



Y07577



Y07578

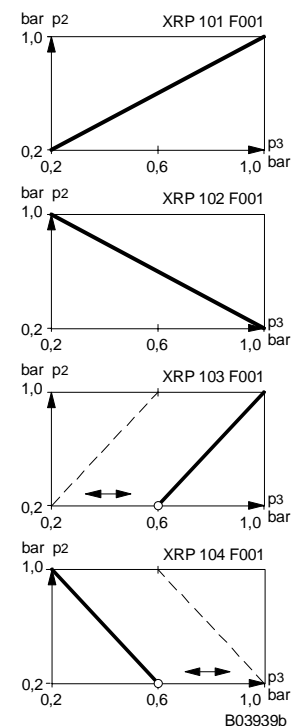

По вопросам продаж и поддержки обращайтесь:

Волгоград +7 (8442) 45-94-42
 Екатеринбург +7 (343) 302-14-75
 Ижевск +7 (3412) 20-90-75
 Казань +7 (843) 207-19-05

Краснодар +7 (861) 238-86-59
 Красноярск +7 (391) 989-82-67
 Москва +7 (499) 404-24-72
 Ниж.Новгород +7 (831) 200-34-65

Новосибирск +7 (383) 235-95-48
 Омск +7 (381) 299-16-70
 Пермь +7 (342) 233-81-65
 Ростов-на-Дону +7 (863) 309-14-65

Самара +7 (846) 219-28-25
 Санкт-Петербург +7 (812) 660-57-09
 Саратов +7 (845) 239-86-35
 Сочи +7 (862) 279-22-65

Connection diagrams

XRP 101, 103, 104

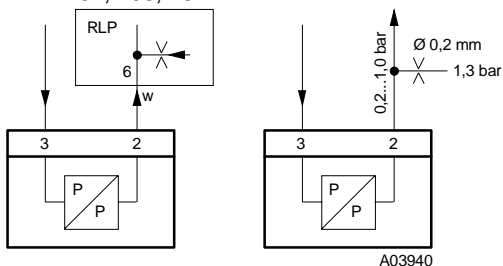

XRP 102

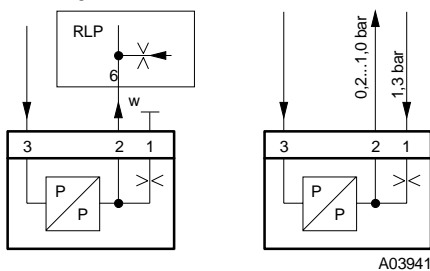

Dimension drawings

XRP 101

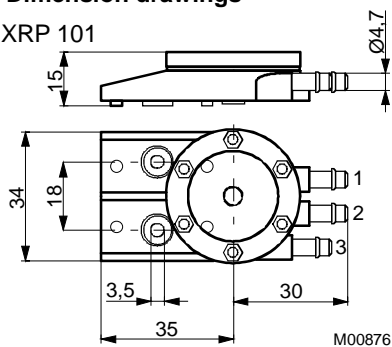

XRP 102, 104

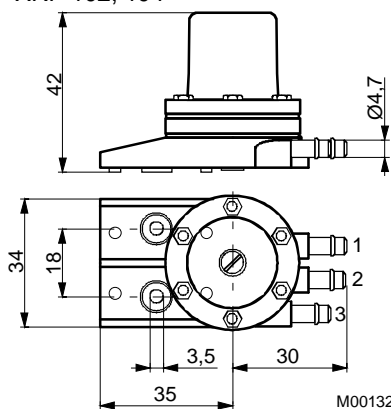

XRP 103

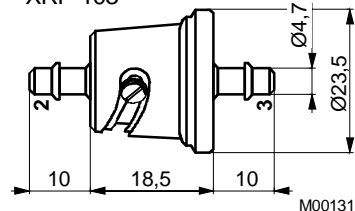

По вопросам продаж и поддержки обращайтесь:

Архангельск +7 (8182) 45-71-35
 Астана +7 (7172) 69-68-15
 Астрахань +7 (8512) 99-46-80
 Барнаул +7 (3852) 37-96-76
 Белгород +7 (4722) 20-58-80
 Брянск +7 (4832) 32-17-25
 Владивосток +7 (4232) 49-26-85
 Владимир +7 (4922) 49-51-33
 Волгоград +7 (8442) 45-94-42
 Воронеж +7 (4732) 12-26-70
 Екатеринбург +7 (343) 302-14-75
 Иваново +7 (4932) 70-02-95
 Ижевск +7 (3412) 20-90-75
 Иркутск +7 (3952) 56-24-09
 Йошкар-Ола +7 (8362) 38-66-61
 Казань +7 (843) 207-19-05

Калининград +7 (4012) 72-21-36
 Калуга +7 (4842) 33-35-03
 Кемерово +7 (3842) 21-56-70
 Киров +7 (8332) 20-58-70
 Краснодар +7 (861) 238-86-59
 Красноярск +7 (391) 989-82-67
 Курск +7 (4712) 23-80-45
 Липецк +7 (4742) 20-01-75
 Магнитогорск +7 (3519) 51-02-81
 Москва +7 (499) 404-24-72
 Мурманск +7 (8152) 65-52-70
 Наб.Челны +7 (8552) 91-01-32
 Ниж.Новгород +7 (831) 200-34-65
 Нижневартовск +7 (3466) 48-22-23
 Нижнекамск +7 (8555) 24-47-85

Новороссийск +7 (8617) 30-82-64
 Новосибирск +7 (383) 235-95-48
 Омск +7 (381) 299-16-70
 Орел +7 (4862) 22-23-86
 Оренбург +7 (3532) 48-64-35
 Пенза +7 (8412) 23-52-98
 Первоуральск +7 (3439) 26-01-18
 Пермь +7 (342) 233-81-65
 Ростов-на-Дону +7 (863) 309-14-65
 Рязань +7 (4912) 77-61-95
 Самара +7 (846) 219-28-25
 Санкт-Петербург +7 (812) 660-57-09
 Саранск +7 (8342) 22-95-16
 Саратов +7 (845) 239-86-35
 Смоленск +7 (4812) 51-55-32

Сочи +7 (862) 279-22-65
 Ставрополь +7 (8652) 57-76-63
 Сургут +7 (3462) 77-96-35
 Сызрань +7 (8464) 33-50-64
 Сыктывкар +7 (8212) 28-83-02
 Тверь +7 (4822) 39-50-56
 Томск +7 (3822) 48-95-05
 Тула +7 (4872) 44-05-30
 Тюмень +7 (3452) 56-94-75
 Ульяновск +7 (8422) 42-51-95
 Уфа +7 (347) 258-82-65
 Хабаровск +7 (421) 292-95-69
 Чебоксары +7 (8352) 28-50-89
 Челябинск +7 (351) 277-89-65
 Череповец +7 (8202) 49-07-18
 Ярославль +7 (4852) 67-02-35

сайт: [gl hf "dfc !gc`i`hcb`fi](http://glhfdfc!gc`i`hcb`fi) | эл. почта: gl f@pro-solution.ru
 телефон: 8 800 511 88 70