

modu532: I/O Модуль, универсальные входы

Как повышается энергетическая эффективность

Технология SAUTER EY-modulo 5: модульный, быстрый и универсальный.

Область применения

Использование цифровых входов (сигнал/статус) и аналоговых входов (Ni/Pt1000, U/I/R) в технических установках, например, HVAC

Характеристики

- Подключаемый модуль для расширения станции автоматизации modu525
- 16 входов
- Модульное проектирование (базовая плата/электроника)
- Питание от CA modu525
- Маркировка непосредственно на передней панели
- Часть серии систем SAUTER EY-modulo
- Возможность подключения к локальному сигнальному устройству (двухцветный LED)

Техническое описание

- 16 универсальных входов (Ni/Pt1000, U/I/R, DI)

Продукт

Тип	Описание
EY-IO532F001	I/O Модуль, универсальные входы

Технические характеристики

Электропитание		Установка	
Питание	от modu525 через шины I/O	Расположение	на широкой рейке
Потребляемая мощность ¹⁾	до 1.2 VA, 0.5 W	Размеры ДхВ хГ (мм)	42 x 170 x 115
Рассеиваемая мощность	до 0.50 W	Вес (кг)	0.285
Потребляемый ток ²⁾	45 mA		
Соединение		Стандарты, нормативы и директивы	
Универсальные входы	16	Степень защиты	IP 30 (EN 60529)
аналоговые	Ni/Pt1000, U/I/R, Pot	Класс защиты	I (EN 60730-1)
цифровые	DI (до 3 Hz)	Окружающий класс	3К3 (IEC 60721)
		СЕ соответствие	
		Директива EMC 2004/108/EC	EN 61000-6-1
			EN 61000-6-2
			EN 61000-6-3
			EN 61000-6-4
Интерфейс, связь		Дополнительная информация	
LO соединение	6-контактное, интегрированное	Инструкция по монтажу	P100001574
Соединение, I/O -шина	12-контактное, интегрированное		P100001575
Соединительные клеммы	24, 0.5...2.5мм ²	Декларация материалов	MD 92.031
		Размерный чертеж	M11416
		Монтажная схема	A10594

1) На лицевой стороне базовой станции modu525 (230 V~)

2) Питание через базовую станцию modu525



T10689

По вопросам продаж и поддержки обращайтесь:

Волгоград +7 (8442) 45-94-42
Екатеринбург +7 (343) 302-14-75
Ижевск +7 (3412) 20-90-75
Казань +7 (843) 207-19-05

Краснодар +7 (861) 238-86-59
Красноярск +7 (391) 989-82-67
Москва +7 (499) 404-24-72
Ниж.Новгород +7 (831) 200-34-65

Новосибирск +7 (383) 235-95-48
Омск +7 (381) 299-16-70
Пермь +7 (342) 233-81-65
Ростов-на-Дону +7 (863) 309-14-65

Самара +7 (846) 219-28-25
Санкт-Петербург +7 (812) 660-57-09
Саратов +7 (845) 239-86-35
Сочи +7 (862) 279-22-65

Engineering notes

The modu532 I/O module generally consists of two components: the baseplate, in which the I/O bus system and connection terminals are integrated, and the actual I/O module electronics.

Installation and assembly

The baseplate of the I/O module is fitted to a top-hat rail (EN 60715) inside a motor control centre and connected on one side directly with the I/O bus of the modu525 automation station or modules. This connection work must be done with the power switched off. The baseplate contains the 'bus module' that is responsible for the power supply and continuous communication. This ensures that disturbances due to a malfunction or partial defect of the electronic component do not affect the functionality of other modules in the sequence.

I/O modules can be inserted into, and removed from, the baseplate whilst the automation station is in operation. In order to protect the installation and to avoid input/output malfunctions, I/O modules should be inserted and removed only when the base station is switched off.

Labelling concept

The I/O module can be labelled by means of a paper insert behind the transparent cover on the front side. These labels are normally inscribed using text generated from within CASE Suite and are printed out on normal DIN A4 paper using generic printers.

Assigning modules to an automation station

The I/O electronic module has hardware pin coding so that only the corresponding baseplate can be used. The modu525 automation station detects whether or not a module baseplate is plugged into the I/O bus. CASE Suite is used to assign the baseplate number and module types of I/O modules to the automation station. This information is stored permanently in the automation station.

LED indicators & function

The I/O module is equipped with a system LED that indicates the following operating conditions:

System LED

LED I/O bus	Condition	Indicator sequence	Description
No name	green continuous	—————	Module in operation
	green pulsating	• • • •	Module not assigned to base station
	red pulsating fast	••••••••••	AS in configuration, update or download mode
	red flashing	• • • • • •	Module incorrectly assigned or internal error
	alternating green, red, off	•• •• •• ••	LED test active (display type has priority)
	no display		No power supply

Description of function

The I/O module has a total of 16 universal inputs.

Universal inputs

Number of inputs 16 (UI)
 Type of inputs Ni1000 (DIN 43760)
 (Software coding) Pt1000 (IEC 751)
 Voltage measurement (U)
 Current measurement (I)
 only on channels u0,u1, u8, u9
 Potentiometer input (Pot)
 Resistance (R)
 Digital input (DI)

Protection against extraneous voltage
 Ni/Pt/U/R/Pot/DI ± 30 V/24 V~ (without damage)
 I (channels u0, u1, u8 ,u9) +12 V, -0.3 V (without damage)

Scan rate
 100 ms channels u0, u5, u8, u12
 500 ms channels u1, u2, u3, u4, u6, u7, u9, u10, u11, u13, u14, u15

Measuring ranges
 Voltage (U) 0 (2)...10 V, 0 (0.2)...1 V
 Current (I) 0 (4)...20 mA
 Potentiometer (Pot) 0...1 (100%) with 3-line connection (1...2.5 kΩ)
 Reference U_{ref} 1.23 V (Terminal no. 22) >1 kΩ, load max. 10 mA
 Resistance (R) 200...2500 Ω
 Temperature Ni1000 -50...+150 °C
 Pt1000 -50...+150 °C
 Digital inputs potential-free contacts, wired to earth
 opto-coupler, transistor (open collector)
 approx. I_{out} = 1.2 mA
 Pulse meter up to 3 Hz

Temperature measurement (Ni/Pt)

The Ni/Pt1000 sensors are connected (using two wires) between one of the input terminals and an earth terminal. Inputs do not require calibration and can be used directly. A corresponding line resistance of 2 Ω is pre-compensated as standard. With a corresponding line resistance of 2 Ω (cross-section: 1.5 mm²), the power cable (wire) may be a maximum of 85 m in length. Greater line resistances can be compensated using the software. The measuring voltage is pulsed so that the sensor does not heat up (I_{Meas} approx. 0.3 mA).

Voltage measurement (U)

The voltage should be measured between one of the input terminals and an earthing terminal. The signal must be potential-free. The measurement ranges with or without offset 0 (0.2)...1 V or 0 (2)...10 V are selected via the software. The input's internal resistance R_i (load) is 9 MΩ.

Current measurement (I)

The current can be measured on four inputs. The current is measured between one of the input terminals (channel u0, u1, u8 or u9) and an earth terminal. The current signal must be potential-free. The measurement ranges with or without offset 0 (4)...20 mA are selected via the software. The maximum input current must be restricted to 50 mA; the internal resistance R_i is < 50 Ω.

Potentiometer measurement (Pot)

The potentiometer is connected between one of the input terminals, an earthing terminal and an U_{ref} terminal (reference voltage). So as not to overload the reference output, the potentiometer value should be at least 1 kΩ. The reference output is not short-circuit-proof. The upper value of 2.5 kΩ is prescribed in order to guarantee stable measurement free of interference.

Note

In order to maintain the measuring accuracy, earthing connections should be occupied with the same type of input.

Digital inputs (DI with UI)

The AS also uses the universal inputs to record binary information. This information (alarm/status) is connected between an input terminal and an earthing terminal. The station applies a voltage of approx. 13 V to the terminal. This usually corresponds to INACTIVE (bit=0) for open contacts. When the contacts are closed, they are ACTIVE (bit=1) and 0 V is applied; the current is

approx. 1 mA. Brief temporary changes (Default 33 ms) are buffered between the station's polling enquiries and are then processed in the next cycle.

Each input can be set as an alarm or a status by configuring the software accordingly.

Digital inputs can be indicated on a local indicating unit (e.g. modu630).

Counter inputs for potential-free contacts, opto-couplers or transistors with an open collector can be connected to the universal inputs.

Technical specifications of inputs and outputs

Universal input	Measuring range	Resolution	Accuracy of measuring span plus measurement value	
Ni/Pt1000	-50...+150 °C	< 0.05 K	± 0.5%	0.5%
U (0/0.2...1 V)	0.02...1.1 V	< 0.1 mV	± 0.5%	0.5%
U (0/2...10 V)	0.15...10.2 V	< 1 mV	± 0.5%	0.5%
I (0/4...20 mA)	0.02...22 mA	< 0.02 mA	± 1%	2%
R	200...2500 Ω	< 0.1 Ω	± 0.2%	1%
Pot (≥ 1 kΩ)	1...100%	< 0.5%	± 1%	1%

Binary input (0-1)	
Switching threshold, active	> 3 V
Switching threshold, inactive	< 1.5 V
Switching hysteresis	> 0.4 V
Pulse meter	up to 3 Hz

Channels and terminals

Description	Channel	Wiring diagram	Signal	Terminals	
					GND
modu532 Universal input (Ni/Pt1000 / U/I/R/Pot / DI) Current signal only at channels 0, 1, 8, 9, or terminals 1, 2, 13, 14,	0	u0	1		
	1	u1	2	3	
	2	u2	4	5	
	3	u3	6	7	
	4	u4	8		
	5	u5	10		
	6	u6	11		
	7	u7	12		
	8	u8	13		
	9	u9	14		
	10	u10	15	16	
	11	u11	17	18	
	12	u12	19	20	
	13	u13	21		
	14	u14	23		
15	u15	24			
Reference voltage 1.23 V		Ref	9		
		Ref	22		

Connecting a local override unit

A modu630 local indicating unit (LOI: Local Override and Indication device) can be added to the I/O module to enable direct indication of digital outputs. The function complies with the EN ISO 16484-2:2004 standard relating to local priority override/indicating units. The unit can be fitted or removed during ongoing operations (hot-plug capability) without impeding any functions of either the automation station or the I/O module.

The modu630 has 16 indicators in the form of bi-colour LEDs. It is possible to define individually whether each input should be an

alarm or a status input. An alarm is usually indicated in red when the contacts are open, and a status is indicated in green when the contacts are closed.

Detailed information and the functions concerning the LED control options can be found in PDS 92.081.

All the LEDs (red + yellow) will flash if an incompatible override unit is connected; there is no danger of damaging the I/O module.

Accessories

EY-LO630F001	Single unit used for indicating data points for I/O module modu532 or AS modu525		
	16 LEDs	LED indicators, bi-colour green/red (freely configurable for event/alarm)	

Dimension drawing

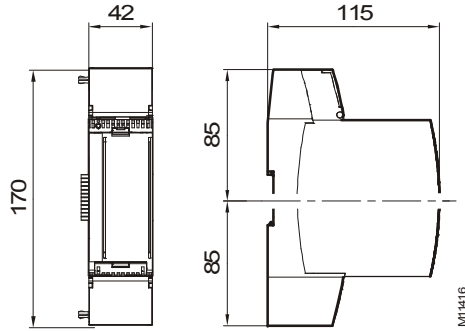

Wiring diagram

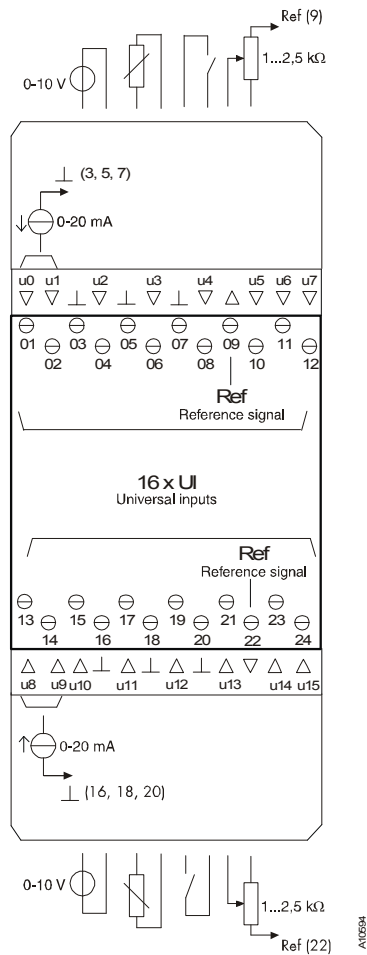

По вопросам продаж и поддержки обращайтесь:

Волгоград +7 (8442) 45-94-42
Екатеринбург +7 (343) 302-14-75
Ижевск +7 (3412) 20-90-75
Казань +7 (843) 207-19-05

Краснодар +7 (861) 238-86-59
Красноярск +7 (391) 989-82-67
Москва +7 (499) 404-24-72
Ниж.Новгород +7 (831) 200-34-65

Новосибирск +7 (383) 235-95-48
Омск +7 (381) 299-16-70
Пермь +7 (342) 233-81-65
Ростов-на-Дону +7 (863) 309-14-65

Самара +7 (846) 219-28-25
Санкт-Петербург +7 (812) 660-57-09
Саратов +7 (845) 239-86-35
Сочи +7 (862) 279-22-65