

modu571: I/O Модуль, цифровые входы/выходы (открытый коллектор)

Как повышается энергетическая эффективность

Технология SAUTER EY-modulo 5: модульный, быстрый и универсальный.

Область применения

Использование цифровых входов (alarm/status) и активация приводов, например, реле, или индикация в технических установках, например, HVAC

Характеристики

- Подключаемый модуль для расширения станции автоматизации modu525
- 16 входов/выходов
- Модульное проектирование (базовая плата/электроника)
- Питание от CA modu525
- Маркировка непосредственно на передней панели
- Часть серии систем SAUTER EY-modulo
- Возможность подключения к локальному сигнальному устройству (двухцветный LED)

Техническое описание

- 16 цифровых входов/выходов (открытый коллектор)

Продукт

Type	Description
EY-IO571F001	I/O Модуль, цифровые входы/выходы (открытый коллектор)

Технические характеристики

Электропитание

Питание	от modu525 через шину I/O
Потребляемая мощность ¹⁾	до 1 VA, 0.4 W
Рассеиваемая мощность	до 0.4 W
Потребляемый ток ²⁾	до 50 mA

Соединение

Цифровые входы/выходы	16
Тип (любая комбинация)	открытый коллектор, NO contacts (0-1) выходы, переключаемые на землю
Напряжение для DO	внешнее, бесперебойное до 24 V=
Нагрузка	до 100 mA
Напряжение для DI	внутреннее, 13.5 V
Счетчик импульсов (DI)	до 10 Hz

Интерфейс, связь

LO соединение	6-контактное, интегрированное
Соединение, I/O –шина	12-контактное, интегрированное
Соединительные клеммы	24, 0.5...2.5мм ²

Допустимые рабочие условия

Рабочая температура	0...45 °C
Температура хранения и транспортировки	-25...70 °C
Влажность	10...85% rh без конденсации

1) На лицевой стороне базовой станции modu525 (230 V~)

2) Питание через базовую станцию modu525

3) Если должен быть выполнен промышленный стандарт (EN 61000-6-2), то шнуры питания должны быть не более 30м в длину.

Установка

Расположение	на широкой рейке
Размеры ДхВ хГ (мм)	42 x 170 x 115
Вес (кг)	0.29

Стандарты, нормативы и директивы

Степень защиты	IP 30 (EN 60529)
Класс защиты	I (EN 60730-1)
Окружающий класс	3К3 (IEC 60721)
CE соответствие	
Директива EMC 2004/108/EC	EN 61000-6-1 EN 61000-6-2 ³⁾ EN 61000-6-3 EN 61000-6-4

Дополнительная информация

Инструкция по монтажу	P100001574 P100001575
Декларация материалов	MD 92.056
Размерный чертеж	M11416
Монтажная схема	A10596



T1.0661

По вопросам продаж и поддержки обращайтесь:

Волгоград +7 (8442) 45-94-42
Екатеринбург +7 (343) 302-14-75
Ижевск +7 (3412) 20-90-75
Казань +7 (843) 207-19-05

Краснодар +7 (861) 238-86-59
Красноярск +7 (391) 989-82-67
Москва +7 (499) 404-24-72
Ниж.Новгород +7 (831) 200-34-65

Новосибирск +7 (383) 235-95-48
Омск +7 (381) 299-16-70
Пермь +7 (342) 233-81-65
Ростов-на-Дону +7 (863) 309-14-65

Самара +7 (846) 219-28-25
Санкт-Петербург +7 (812) 660-57-09
Саратов +7 (845) 239-86-35
Сочи +7 (862) 279-22-65

Engineering notes

The modu571 I/O module generally comprises two components: the baseplate, in which the I/O bus system and connection terminals are integrated, and the actual I/O module electronics.

Installation and assembly

The baseplate of the I/O module is fitted to a top-hat rail (EN 60715) inside a motor control centre and connected on one side directly with the I/O bus of the modu525 automation station or modules. This connection work must be done with the power switched off.

The baseplate contains the 'bus module' that is responsible for the power supply, the continuous communication and optional back-up supply. This ensures that disturbances due to a malfunction or partial defect of the electronic component do not affect the functionality of other connected modules.

I/O modules can be inserted into, and removed from, the baseplate whilst the automation station is in operation.

In order to protect the installation and to avoid input/output malfunctions, I/O modules should be inserted and removed only when the base station is switched off.

System LED

LED I/O bus	Condition	Indicator sequence	Description
No name	green continuous	—————	Module in operation
	green pulsating	• • • • •	Module not assigned to base station
	red pulsating fast	••••••••••	AS in configuration, update or download mode
	red flashing	• • • • •	Module incorrectly assigned or internal error
	alternating green, red, off	•• •• •• ••	Lamp test active (display type has priority)
	no display		No power supply

Description of function

The I/O module has a total of 16 digital inputs/outputs. Each hardware connection can be set individually as an input (DI) or an output (DO) by setting software parameters accordingly; only one function is possible in each case.

Digital inputs

Number of inputs	16
Type of inputs	potential-free contacts, wired to earth opto-coupler transistor (open collector)
Pulse meter	up to 10 Hz (100 ms scan rate)
Pulse status	> 4 ms
Protection against extraneous voltage	± 30 V / 24 V~ (without damage)
Max. output current	1.2 mA (source) with respect to earth
Scan rate	100 ms

Binary information is connected between one of the input terminals and earth. The module applies approximately 13 V to the terminal. This corresponds to INACTIVE (bit=0) for open contacts. When the contacts are closed, it is ACTIVE (bit=1) and 0 V is applied, and the current is approx. 1 mA. Brief temporary changes of at least 20 ms are buffered between the station's polling enquiries and are then processed in the next cycle.

Each input can be set as an alarm or a status by configuring the software accordingly.

Digital inputs can be indicated on a local indicating unit (e.g. modu630).

Pulse counter (CI with DI)

Counter inputs for potential-free contacts, opto-couplers or transistors with an open collector can be connected to the digital inputs. The maximum pulse frequency may reach 10 Hz. To ensure that switched contacts are registered correctly, provision is made for a

Labelling concept

The I/O module can be labelled by means of a paper insert behind the transparent cover on the front side. These labels are normally inscribed using text generated from within CASE Suite and are printed out on normal DIN A4 paper using generic printers.

Assigning modules to an automation station

The I/O electronic module has hardware pin coding so that only the corresponding baseplate can be used. The modu525 automation station detects whether a module baseplate is plugged into the I/O bus. CASE Suite is used to assign the baseplate number and module types of I/O modules to the automation station. This information is stored permanently in the automation station.

LED indicators & function

The I/O module is equipped with a system LED that indicates the following operating conditions:

de-bounce time of 5 ms. Pulses can be detected on falling, rising or both edges; the minimum pulse time should be four times the de-bounce time.

Digital outputs	16
Type	Digital, transistor open collector switched to ground/earth
Digital output	24 V=, up to 100 mA (sink)
Length of power lead:	up to 30 m
Processing cycle	100 ms

The open-collector output (OC) can be supplied with up to 24 V=; the signals are with respect to earth/ground. Devices are connected via screw-type terminals, which must be done with power switched off.

All open-collector outputs are equipped with a protective circuit. If relays with integrated protection (e.g. suppressor diode) are fitted, attention must be paid to correct polarity.

Genuine feedback signals are possible only via digital inputs.

Note

If the industrial standard (EN 61000-6-2) has to be met, the power cables for digital open-collector outputs (DO-OC) should be no more than 30 metres in length.

Preset switching statuses in the event of a defective module are guaranteed by an independent, internal cut-off facility. This prevents the outputs from flickering.

The open-collector outputs assume the preset status '0' (off) if:

- the power supply/communication on the I/O bus is interrupted
- the power supply to the automation station fails.

Channels and terminals

Description	Channel	Wiring diagram	DI/DO	Terminals	
					GND
modu551					
Digital input/output Transistor open collector	0	od0	1		
	1	od1	2	3	
	2	od2	4	5	
	3	od3	6	7	
	4	od4	8	9	
	5	od5	10		
	6	od6	11		
	7	od7	12		
	8	od8	13		
	9	od9	14		
	10	od10	15	16	
	11	od11	17	18	
	12	od12	19	20	
	13	od13	21	22	
	14	od14	23		
	15	od15	24		

Connecting a local override unit

A modu630 local indicating unit (LOI: Local Override and Indication device) can be added to the I/O module to enable direct indication of digital outputs. The function complies with the EN ISO 16484-2:2004 standard relating to local priority override/indicating units. The unit can be fitted or removed during ongoing operations (hot-plug capability) without impeding any functions of either the automation station or the I/O module.

- EY-LO630F001: 16 LEDs
- EY-LO650F001: 6 switches (Automatic 'A', 0-I) with LED indicators
- EY-LO650F002: 3 switches (Automatic 'A', 0-I-II) with LED indicators

The local override/indication units can be fitted or removed during ongoing operations (hot-plug capability) without impeding any functions of either the automation station or the I/O module.

Detailed information on the control functions and the LED indicators can be found in PDS 92.081.

All the LEDs (red + yellow) will flash if an incompatible override unit is connected; there is no danger of damaging the I/O module.



Note

Before using an override/indication unit, all the switch positions (auto) should be checked to ensure that no undesirable switching operations are carried out. On removing the unit, all outputs are run with the automatic statuses of the I/O module.

In keeping with the applicable standard, the local override and indication devices allow the restricted operation of plant components without involving the automation station intended for the application.

Outputs that are in manual operating mode may temporarily change value during a user program download. The local override unit can be used to control channels 0...5 directly in the automation station even without a user application (CASE Engine).

Areas of application

EY-LO630F001	Single unit used for indicating data points for I/O module modu571 or AS modu525		
	16 LEDs	LED indicators, bi-colour green/red (freely configurable for event/alarm)	
EY-LO650F001	Single unit used for indicating data points for I/O module modu571 or AS modu525		
	4 LEDs	LED indicators, bi-colour green/red (freely configurable for event/alarm)	
	6 switches with LED indicator	Auto-0-I, indicating, green Indicating manual position, yellow	
EY-LO650F002	Single unit used for indicating data points for I/O module modu571 or AS modu525		
	4 LEDs	LED indicators, bi-colour green/red (freely configurable for event/alarm)	
	3 switches with LED indicator	Auto-0-I-II, indicating, green Indicating manual position, yellow	

Dimension drawing

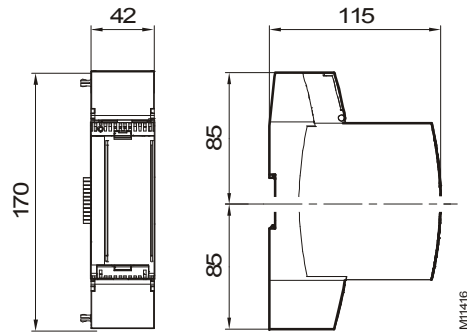

Wiring diagram

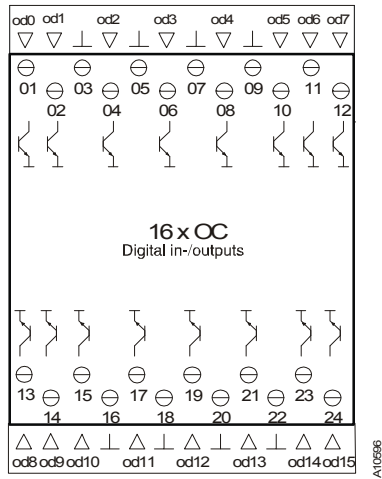

По вопросам продаж и поддержки обращайтесь:

Волгоград +7 (8442) 45-94-42
Екатеринбург +7 (343) 302-14-75
Ижевск +7 (3412) 20-90-75
Казань +7 (843) 207-19-05

Краснодар +7 (861) 238-86-59
Красноярск +7 (391) 989-82-67
Москва +7 (499) 404-24-72
Ниж.Новгород +7 (831) 200-34-65

Новосибирск +7 (383) 235-95-48
Омск +7 (381) 299-16-70
Пермь +7 (342) 233-81-65
Ростов-на-Дону +7 (863) 309-14-65

Самара +7 (846) 219-28-25
Санкт-Петербург +7 (812) 660-57-09
Саратов +7 (845) 239-86-35
Сочи +7 (862) 279-22-65