

ecoLink510...512: Полевой модуль входы/выходы

Как повышается энергетическая эффективность

Модульная технология для оптимальной работы приложений. Сокращение расходов на проводку.

Область применения

Регулирование, управление, мониторинг и оптимизация технических систем, как например, комнатной автоматизации HVAC. Связь подключаемых приводов со станции автоматизации

Характеристики

- Полевой модуль входы/выходы для ecos500
- Часть семейства систем SAUTER EY-modulo 5
- Расположение до 500 метров от станции автоматизации

Техническое описание

- Напряжение питания: 24 V~
- Шина данных EIA-485, SLC протокол

Продукция

Тип	Описание
EY-EM510F001	Полевой модуль входы/выходы, 24 V~, 3 реле, 3 триак
EY-EM511F001	Полевой модуль входы/выходы, 24 V~, 3 триак
EY-EM512F001	Полевой модуль входы/выходы, 24 V~, 2 триак



Техническая информация

Электрическое питание

Питание	24 V~, ± 20%, 50...60 Hz
Потребляемый ток	До 500 mA
	Не включая токовую нагрузку на выходы триак и реле
Рассеиваемая мощность	До 10 W (обычно около 4 W)

Входы/выходы

Выходы реле	0-I, N/O контакты
Нагрузка	230 V~/ 5 A ³⁾ (общая макс. 10 A)
Количество переключений	> 5 × 10 ⁶ циклов
Триак выходы	0-I, 24 V~/ 0.5 A
Аналоговые выходы	0-10 V= / 2 mA
Аналоговые/цифровые выходы	0...10 V / 0-I
Ni1000/Pt1000 входы	-20...100 °C

Интерфейсы, связь

Управление	через ecos500
Связь с ecos500	До 500 м (зависит от типа кабеля) ⁴⁾

Обзор входов/выходов

	EY-EM510	EY-EM511	EY-EM512
Реле	3	0	0
Триак	3	3	2
0...10 V Выход	3	3	2
Ni/Pt1000	2	2	0
0...10 V Вход, цифровой вход	4	4	4

Допустимые условия среды

Рабочая температура	0...45 °C
Хранение и транспортировка	-25...70 °C
Влажность	10...85 % rh Без конденсации

Установка

Размеры Д x В x Г (мм)	105 × 95 × 60
Вес (кг)	0.215

Стандарты, директивы

Степень защиты	IP00 (EN 60730) ²⁾
Класс защиты EY-EM510	II (EN 60730-1)
EY-EM511, EY-EM512	III (EN 60730-1)
Окружающий класс	3К3 (IEC 60721)
CE соответствие	
EMC Директива 2004/108/EC	EN 61000-6-1 EN 61000-6-2 ¹⁾ EN 61000-6-3 EN 61000-6-4
Электробезопасность 2006/95/EC	EN 60730-1

Дополнительная информация

Инструкция по монтажу	P100002346
Декларация материалов	MD 92.845
Размерный чертёж	M11463
Схема подключения EY-EM510	A10653
EY-EM511	A10654
EY-EM512	A10655

1) Для соответствия промышленному стандарту EN 61000-6-2, подсоединяемые кабели должны быть не более 30 м в длину.

2) IP20 с крышкой для клемм (аксессуар 0900240020), IP40 фронтальная защита после монтажа

3) См. раздел о цифровых выходах (реле)

4) См. раздел инженерные записи

По вопросам продаж и поддержки обращайтесь:

Волгоград +7 (8442) 45-94-42
Екатеринбург +7 (343) 302-14-75
Ижевск +7 (3412) 20-90-75
Казань +7 (843) 207-19-05

Краснодар +7 (861) 238-86-59
Красноярск +7 (391) 989-82-67
Москва +7 (499) 404-24-72
Ниж.Новгород +7 (831) 200-34-65

Новосибирск +7 (383) 235-95-48
Омск +7 (381) 299-16-70
Пермь +7 (342) 233-81-65
Ростов-на-Дону +7 (863) 309-14-65

Самара +7 (846) 219-28-25
Санкт-Петербург +7 (812) 660-57-09
Саратов +7 (845) 239-86-35
Сочи +7 (862) 279-22-65

Engineering notes

The ecoLink field modules can be installed on a top-hat rail directly in the cabinet or at a suitable location in the system. The plant devices are connected using screw terminals; the system must always be disconnected from the power supply before carrying out this work.

Note:

On the ecoLink modules, the earth cable (MM) is connected to the technical earth (GND) and the common connection (c) of the RS485 interface. On the EY-modulo 5 ecos, the technical earth is connected to the protective earth. When using an external 24 V~ transformer, this means one 24V end is automatically earthed. When using non-Sauter devices, isolation measures may be necessary in order to prevent a short circuit.

Some lower-power transformers generate excess voltage, which in rare cases may cause unwanted heating of the ecoLink modules. A reference list of approved transformers is available on request.

The maximum permissible bus length depends on the type of cable used and the correct use of terminating resistors. For Ethernet CAT-5 cables and IYST-Y cables, the maximum bus length is 500 m. The bus must be wired in a line topology. Start, tree or branching topologies are not recommended. The ecos500 room automation station has a 3-wire bus connection to the RS485-B interface. Make sure the polarity is correct. The devices do not have internal terminating resistors.

Avoid laying sensor wires parallel to cables carrying power current. When laying wires for analogue signals, such as the 0...10 V inputs/outputs and the NI/PT1000 inputs, there must be a separate earth connection from the ecoLink module to the sensor or actuator for each input and output. Common earth cables cause measurement errors, which can impair low-voltage measuring signals in particular.

Addressing / baud rate

Value	Off	On
1		x
2		x
4		x
8		x
16	x	
32	x	
64	x	
128	x	

Up to 16 modules can be connected to a bus line. These must be unambiguously addressed. An 8 DIL switch is provided for this. S1: 1-8: Valid address range: 1-16.

The baud rate is fixed at 115 kBaud.

Installation and power supply

ecoLink field modules are compact devices that are suitable for wall mounting or for DIN 43880 series installation on a 35 mm top-hat rail. The plant devices are connected using screw terminals. The following conditions must be met:

- The devices may only be connected when the system is disconnected from the power supply.
- The unit must be protected against contact.
- The earth terminals are connected internally to the earth connector (PE) (PELV circuits).

Wire cross-section: minimum 0.8 mm² (AWG 18), maximum 2.5 mm² (AWG 13), in accordance with standards and installation regulations.

The communication wiring must be professionally installed and kept away from other live wires. An external fuse as stipulated by the installation regulations must be installed in series with terminal

LS, the 24V~ power supply. At maximum output load, a fuse rating of 4A slow-blow is recommended.

Specific standards such as IEC/EN 61508, IEC/EN 61511, IEC/EN 61131-1 and -2 have not been taken into account. Local regulations regarding installation, use, access, access rights, accident prevention, safety, removal and disposal must be complied with. The installation standards EN 50178, 50310, 50110, 50274, 61140 and similar must be adhered to.

For more information see the fitting instructions P100007169.

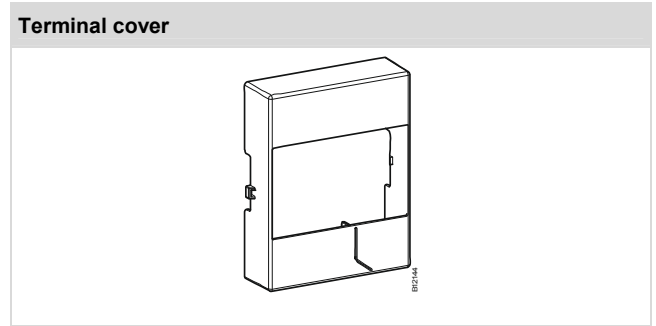

Accessory component 0900240020. When the cover is fitted on the ecoLink module, it provides IP20 protection. When fitted, the frontal protection is IP40.

Technical specifications of the inputs and outputs

Inputs

When fully equipped, 6 inputs are available: 2 Ni1000/Pt1000 and 4 analogue inputs for active signals.

If the analogue inputs (0...10 V) are to be used as digital inputs, they must be connected to the 15 V support terminal. With this wiring, the inputs are defined as digital inputs using the CASE tool. This 15 V terminal is only for digital inputs.

Input types:
(Software coding) Ni1000 (DIN 43760)
Pt1000 (IEC 751)
Voltage measurement (U)
Current measurement (I) (with external resistor)
Digital input (DI)

Protection against degree of protection:
Ni/Pt/U/DI ± 30 V / 24 V~ (non-destructive)

Resolution 10 Bit
Scan rate ≤ 100 ms (analogue/digital values)
Refresh rate ≤ 300 ms (EY-modulo 5 ecos)

Measuring ranges:
Voltage (U) 0 (2)...10 V=
Current (I) (via external R)0 (4)...20 mA
Temperature
Ni1000 -20...+100 °C
Resolution < 0.5 K
Pt1000 -20...+100 °C
Resolution < 1 K
Digital input Potential-free contacts, connected to 15 V. As counter input, max. 2 Hz (min. pulse duration 250 ms)

Temperature measurement (Ni/Pt)

The Ni/Pt1000 sensors are connected with two wires between one of the input terminals and an earth terminal. The inputs do not need calibration and can be used directly. A corresponding line resistance 2 Ω is already compensated for as standard. With the corresponding line resistance of 2 Ω (cable cross-section 1.5 mm²), the connecting cable (wire) can be up to 85 m long. Higher line resistance can be compensated for using the software. The input wiring is designed so that with the above measuring range and the 10-bit AD converter, the connected sensors are triggered at exactly 1 Ω.

Voltage measurement (U)

The voltage to be measured is connected between an input terminal and an earth terminal. The signal must be potential-free. The internal resistance R_i of the input (load) is 100 k Ω .

Current measurement (I)

Current measurement of 0(4)...20 mA is possible via an external resistor (e.g. 500 Ω). The current to be measured is connected parallel to the resistor between one of the input terminals and an earth terminal. The current signal must be potential-free. A separate ground terminal must be used for the current measurement. Otherwise, zero offset may lead to inaccurate measurements for other signals.

Digital inputs (DI)

The information (alarm/status) is connected between an input terminal and the 15 V support terminal. When a contact is open, this corresponds to the inactive state (bit=0). When the contact is closed, it is active (bit=1) and 15 V is present at the input, with a current of approximately ~0.3 mA flowing.

Every input can be defined individually as alarm or status using software parameters.

Outputs

When fully equipped, 9 outputs are available: 3 relays, 3 Triacs, 3 analogue (0...10 V). The outputs are refreshed every 200 ms by the ecos system (EY-RC500).

Digital outputs (relays)

Number of outputs	Max. 3 (DO)
Type of output	Relay, N/O contacts (0-I)
Output load	230 V~ / 5 A
Switching frequency	10 ⁶ cycles
Switching voltage	24...250 V

The relay contacts are for actuating the fan coil ventilators. The relays have an increased starting current capacity. The peak starting current at the N/O relay current (working contact) is 80 A for up to 20 ms. They are supplied via the shared terminal 24.

During operation, the total current via this terminal may not exceed 10 A.

The digital outputs can be defined for single-stage or multi-stage functions. Genuine responses can only be implemented via digital inputs (BACnet COMMAND-FAILURE).

Digital outputs (Triac)

Number of outputs	max. 3 (DO)
Type of output	Triac, N/O contacts (0-I)
Output load	24 V~ / 0.5 A (ohmic load)

The actuator to be controlled (e.g. thermal actuator drive) is directly connected to the Triac terminals. The Triacs are connected to GND and can be defined for single-stage or multi-stage functions. Genuine responses can only be implemented via digital inputs (BACnet COMMAND-FAILURE). The power supply for thermal actuator drives can be taken from the LS terminals.

Analogue outputs

Number of outputs	Max. 3 (AO)
Output type	0(2)...10 V
Load	≤ 2 mA
Attack time	1 s
Resolution	0.1 V
Signal deviation	< +4% of the set value

The output voltage is picked up between the corresponding output terminal and the earth terminal. The outputs are push-pull outputs with active sink capability. Each output can carry 2 mA.

The analogue output is protected against shorting to earth, but is not protected from disturbance voltage. However, constant shorting of multiple outputs will cause them to be irreparably damaged by heat. There is also protection against static discharge.

LED indicator

Status	Description
LED off	Device out of operation
Constant green light	Device in operation
Flashing green light	Device communicating with ecos500 but not addressed
Constant red light	Device not ready (No program loaded)
Flashing red light	Device not communicating with ecos500
Pulsating red light	Internal device error
Constant orange light	Power-up phase, configuration

The multicoloured LED on the ecoLink module indicates the operating status.

Start-up procedure / monitoring functions

The communication between the ecos500 and the ecoLink modules is monitored. If the communication fails, the data points are marked in the ecos500 with the status "unreliable". Similarly, the corresponding data points are shown with a reliability property when internal device errors occur.

The following operating modes are distinguished:

a) ecos500 in operation, ecoLink module power up
When the ecos500 detects an ecoLink powering up, communication to that module starts immediately. The following actions are performed:

- Loading the module parameters (e.g. "communication monitoring timer": default = 10 s, "Timer command delay" (OFF after ON): default = 200 ms)
- If there have been changes to the status of the ecos500 while the ecoLink module was online (e.g. ON/OFF commands), OFF commands are executed in the ecoLink module immediately and ON commands after 200 ms.

b) ecos500 and ecoLink module power up
The start-up procedures (power up) of the ecos500 and ecoLink are different. The "Power up timer" parameter in the ecoLink (default = 1 s) defines the period that the ecoLink waits until it begins monitoring communication. This means the start-up procedure can be synchronised with that of the ecos500. This parameter can be set individually for each ecoLink module (value range 1...254 s). This setting is made using the SAUTER CASE Suite software. Until the "power up timer" is completed, the analogues are kept in a state similar to the de-energised condition (safe mode).

c) ecoLink in operation, ecos500 power up
If the ecos500 powers up and the ecoLink module is in safe mode (power up timer completed), the first permissible communication values are immediately applied, and the OFF to ON command transitions are not activated until after the timer command delay.

Integrating the ecoLink modules using CASE Suite

The ecoLink modules are planned using CASE Suite. Depending whether the ecos500 is designed for one, two or four axes, the device addresses 1-16 are displayed in a table. The device addresses are mirrored for a multi-axis ecos500.

One ecoLink module can then be assigned to each of these addresses. After this, the data points are defined and assigned to the corresponding modules with their channel connections. This allows the inputs and outputs to be directly mapped to BACnet data points.

ecos500 device addresses

1 axis	2 axes	4 axes
1		
2	1=9	
3	2=10	

4	3=11	1=5= 9=13
5	4=12	2=6=10=14
6	5=13	3=7=11=15
7	6=14	4=8=12=16
8	7=15	
9	8=16	
...		
16		

Dimension drawing

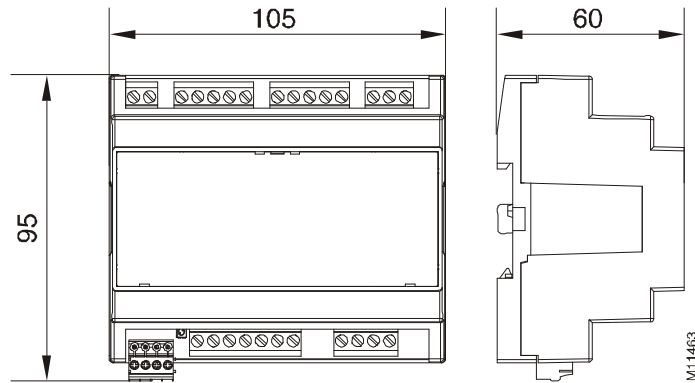

Wiring diagram

EY-EM510

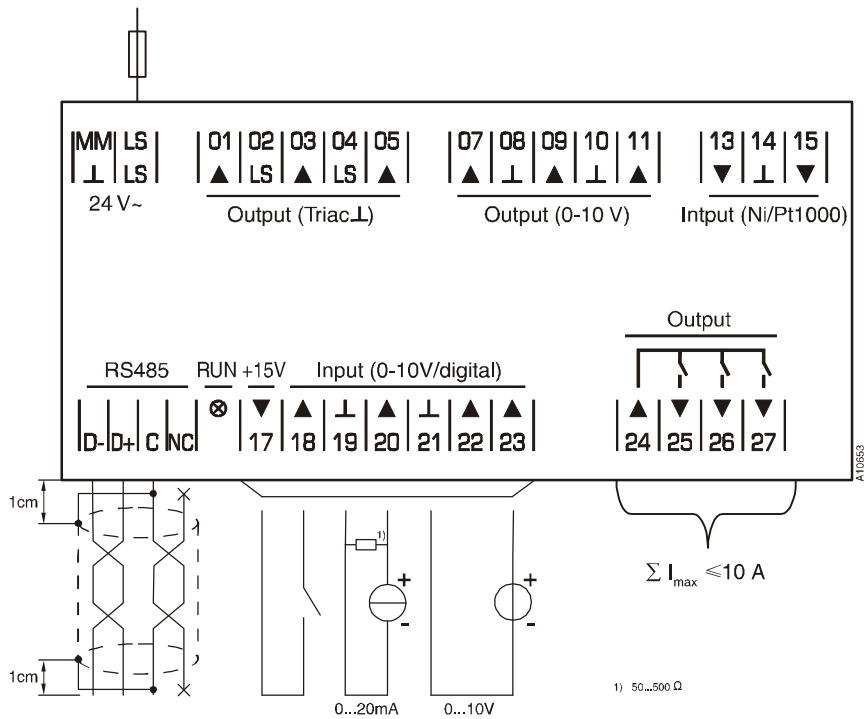

Wiring diagram (continued)

EY-EM511

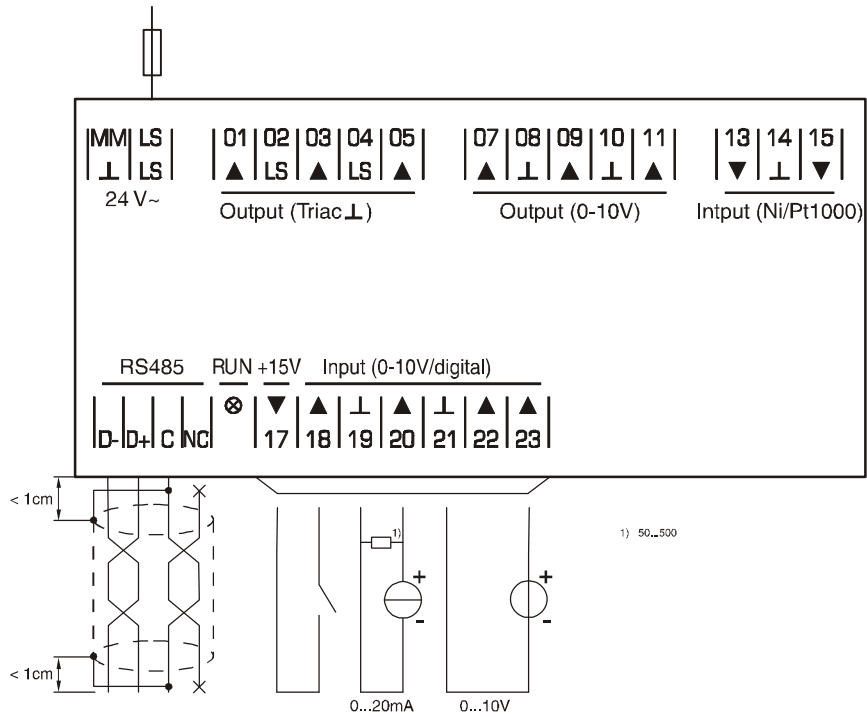

EY-EM512

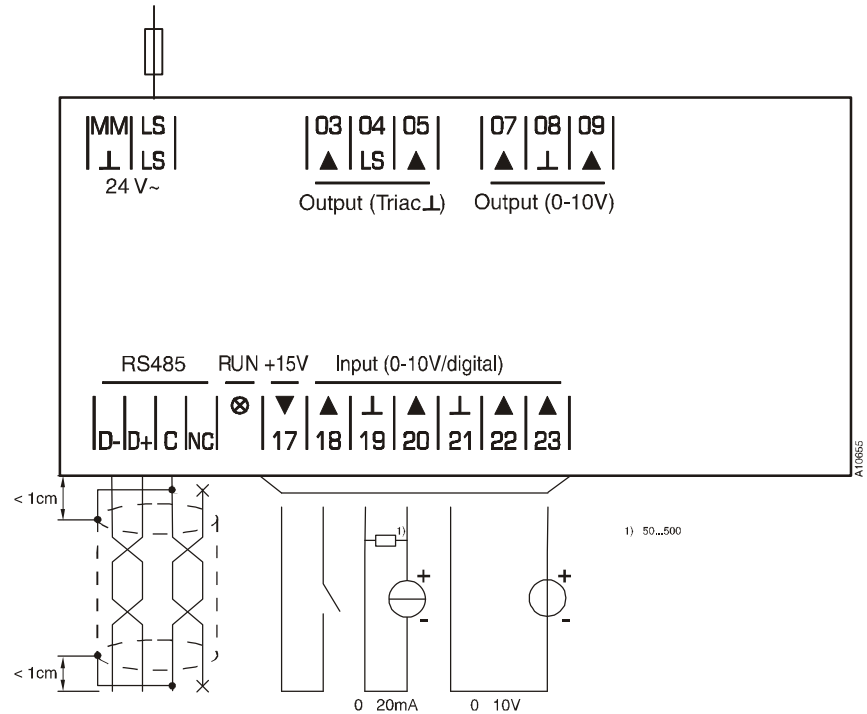

По вопросам продаж и поддержки обращайтесь:

Волгоград +7 (8442) 45-94-42
 Екатеринбург +7 (343) 302-14-75
 Ижевск +7 (3412) 20-90-75
 Казань +7 (843) 207-19-05

Краснодар +7 (861) 238-86-59
 Красноярск +7 (391) 989-82-67
 Москва +7 (499) 404-24-72
 Ниж.Новгород +7 (831) 200-34-65

Новосибирск +7 (383) 235-95-48
 Омск +7 (381) 299-16-70
 Пермь +7 (342) 233-81-65
 Ростов-на-Дону +7 (863) 309-14-65

Самара +7 (846) 219-28-25
 Санкт-Петербург +7 (812) 660-57-09
 Саратов +7 (845) 239-86-35
 Сочи +7 (862) 279-22-65